

**BHARAT HEAVY ELECTRICALS LIMITED**

[A Government of India Undertaking]

Ramachandrapuram, Hyderabad, 502032, A.P. India  
Phone 040-23184526, 23182322 FAX:040-23021910, 1954**भारत हेवी इलेक्ट्रिकल्स लिमिटेड**

(भारत सरकार का उपक्रम)

रामचन्द्रपुरम, हैदराबाद, 502032 आंध्र प्रदेश, भारत

RFQ NO :

**PURCHASE DEPARTMENT****ENQUIRY****क्रय विभाग**

जांच (ई मेल : tenderbox@bhelhyd.co.in)

SHEET:1  
OF :2HY17001 C  
REV.NO.0Phone 091-40-23184526  
091-40-23182322FAX : 091-40-23021910  
091-40-23021954**PURCHASE DEPARTMENT**

GSTIN:

Enq/Collective No :D3A1R78853

Enq.Dt. : 15.03.2018

No.Of Items :\*

DUE Dt. OF QUOTN. : 05.04.2018

**Office Copy**

Please submit your lowest quotation in sealed cover superscribed with Enquiry No./Collective No.(RFQ No ..... ) and due date subject to our terms and conditions attached ,for the materials mentioned below. Your offer has to reach us on or before due date by 11.00 Hours (IST) and will be opened at 14.00 Hours.(IST).If our Enquiry No./Collective No.(RFQ No ..... ) and tender due date are not super scribed on the tender cover , your offer shall be summarily rejected. Incomplete offers and late offers will not be considered.

SL NO	Purchase Req.no	item no	Material Code, HSN No.	Drg no - Ver , Rev & Spec - Ver , Rev,Spec-Var	Description	Unit	Qty	Delivery Date	Schedule Qty
1	8000078853	80	HE9718583262 7304	31750102457,00 HE51173,10,NA	SS SMLS U TUBES (O.D 15.875 X 9800LL)	EA	6,692.000	31.12.2018	1,673.000
2	8000078853	10	7304					31.12.2018	1,673.000
3	8000078853	20	7304					31.12.2018	1,673.000
4	8000078853	70	7304					31.12.2018	1,673.000
5	8000078853	100	HE9718583270 7304	31750102457,00 HE51173,10,NA	SS SMLS U TUBES (O.D 15.875 X 11300LL)	EA	6,692.000	31.12.2018	1,673.000
6	8000078853	30	7304					31.12.2018	1,673.000
7	8000078853	40	7304					31.12.2018	1,673.000
8	8000078853	90	7304					31.12.2018	1,673.000
9	8000078853	120	HE9718583289 7304	31750102457,00 HE51173,10,NA	SS SMLS U TUBES (O.D 15.875 X 8700LL)	EA	6,692.000	31.12.2018	1,673.000
10	8000078853	50	7304					31.12.2018	1,673.000

TEST CERTIFICATE REQD: Y  
GUARANTEE REQ : Y  
SAMPLE REQD : N  
BID TYPE : TWO PARTFor and on-behalf of  
Bharat Heavy Electricals Limited.CH. KARTHIK  
Officer/Pur(HE&F)Ph.No.040231822  
02

**BHARAT HEAVY ELECTRICALS LIMITED**

[A Government of India Undertaking]

Ramachandrapuram, Hyderabad, 502032, A.P. India  
Phone:040-23184526, 23182322 FAX:040-23021910, 1954**भारत हेवी इलेक्ट्रिकल्स लिमिटेड**

(भारत सरकार का उपक्रम)

रामचन्द्रपुरम, हैदराबाद, 502032 आंध्र प्रदेश, भारत

RFQ NO :

**PURCHASE DEPARTMENT****ENQUIRY****क्रय विभाग**

जांच (ई मेल : tenderbox@bhelhyd.co.in)

SHEET:2  
OF :2

HY17001 C REV NO.0	Phone 091-40-23184526 091-40-23182322	FAX : 091-40-23021910 091-40-23021954	<b>PURCHASE DEPARTMENT</b>			
GSTIN:		Enq/Collective No :D3A1R78853	Enq.Dt : 15.03.2018	No.Of Items :*	DUE Dt. OF QUOTN : 05.04.2018	

**Office Copy**

Please submit your lowest quotation in sealed cover superscribed with Enquiry No./Collective No.(RFQ No ..... ) and due date subject to our terms and conditions attached ,for the materials mentioned below.Your offer has to reach us onor before due date by 11.00 Hours (IST) and will be opened at 14.00 Hours.(IST).If our Enquiry No./Collective No.(RFQ No ..... ) and tender due date are not super scribed on the tender cover , your offer shall be summarily rejected. Incomplete offers and late offers will not be considered.

SL NO	Purchase Req.no	item no	Material Code, HSN No.	Drg no - Ver , Rev & Spec - Ver , Rev,Spec-Var	Description	Unit	Qty	Delivery Date	Schedule Qty
11	8000078853	60	7304					31.12.2018	1,673.000
12	8000078853	110	7304					31.12.2018	1,673.000
13	8000080920	40	HE9718584471	41750103324,00 HE51173,10,NA	SS SMLS U TUBES (OD15.875X 4600LL)	EA	3,032.000	31.12.2018	758.000
14	8000080920	10						31.12.2018	758.000
15	8000080920	20						31.12.2018	758.000
16	8000080920	30						31.12.2018	758.000

Special Remarks

**CheckList of Quality Interventions:**  
 "Vendors are requested to update GSTIN details in PRADAN portal (<https://web.bhelhyd.co.in/mm/>) by 30.05.2017".

**BHEL reserves the right to enforce any or all of the following checks during execution of the order.**  
**There is no additional cost to the vendor on account of these checks.**

Digitally signed  
 by CHEETIRALA  
 KARTHIK

TEST CERTIFICATE REQ: Y  
 GUARANTEE REQ: Y  
 SAMPLE REQD: N  
 BID TYPE: TWO PART

For and on behalf of  
 Bharat Heavy Electricals Limited.  
 Date: 2018.03.15  
 15:19:35  
 CH. KARTHIK  
 Officer/Pur(HE&P)P.No.040231822

**PRE-QUALIFICATION CRITERIA**

**S.S. Seamless U Tubes for High Pressure Feed Water Heater Application**

S.No.	BHEL Requirement	Vendor's Confirmation	Deviation if Any	Remarks
1	All the suppliers need to submit this document i.e. titled pre-qualification criteria and furnish required information along with offer.			
2	<p>a) Name, address, e-mail id, contact no.etc. of manufacturing mill for SS Seamless U Tubes.</p> <p>b) Name, address, e-mail id, contact no.etc. of authorised agency / trading house quoting on behalf of manufacturing mill. In case offer is received from authorised agency / trading house, the following requirements shall be full filled.</p> <p>i) Valid letter of authorisation and copy of agreement to be enclosed with offer.</p> <p>ii) The offer should be either from the authorised agency or from the manufacturer directly. In case of BHEL receiving offer from both, then offer from manufacturer will only be considered. Offer from an unauthorised agency / entity on behalf of any vendor shall be summarily rejected.</p> <p>iii) Name, address, e-mail id, contact no.etc. of entity on whom order to be released in case of L1 shall be clearly indicated.</p>			
3	Supplier to confirm/provide the following criteria/documents for evaluation of offer.			
	(a) The supplier should have the proven experience in manufacturing and supply of Stainless Steel seamless U tubes for High Pressure Feed water heater in power plant application as mentioned below.			
	i) Material : SA 213 TP 304 /SA 213 TP 304 N / SA 213 TP 304L / SA 213 TP 304LN			
	ii) Tube O.D. : 15.875 mm (5/8 inch)			
	iii) Tube Thickness : 2.1 mm minimum or thicker			
	iv) Application: High Pressure Feed water heater (HP Heater).			
	v) Service: Power plant.			
	vi) Satisfactory Working of equipment: At least one year in a power plant ending lastday of month previous to the one in which enquiry floated.			
	vii) The supplier shall be an original U-Tube manufacturer. All the facilities required for manufacturing U-tubes from mother hollows or round bars, shall be readily available with the vendor. Ex: Bright annealing facility, online or offline eddy current testing facility, Ultrasonic test facility,Hydrostatic testing facility. (Hydrostatic test pressure:585 kg/sq.cm (g) minimum), U-bend stress relieving facility etc.			
	viii) The mother hollows shall be manufactured by hot extrusion method, other methods are not acceptable.			
	All the above criteria 3(a) (i) to 3(a) (viii) must be combinedly met by the vendor against a single supply reference of U tubes.			
	Supplier's having experience in other applications other than High Pressure Feed Water Heaters in a Power plant will not be treated as a proven experience.			
	(b) The supplier meeting all the above criteria as 3 (a) (i) to 3 (a) (viii) shall furnish details of such supplies only as indicated above ( sl no 3 (a)) including equipment (HP Heater) Manufacturer's Name, power plant name, date of supply (in DDMMYY format), No of years the equipment (HP Heater) is in service, Size, Quantity and full contact details of equipment (HP Heater) Manufacturer & power plant. (including mobile no and e-Mail ID) OR Heater Manufacturer's certificate (in English) containing the supply details as above both 3(a) & 3 (b), Contact details [E-Mail ID, Land line/Mobile No.] and complete address of Heater Manufacturer may be furnished.  <b>Note</b> : Suppliers shall furnish maximum upto 6 number of latest customer reference details as indicated above in the attached annexure-I. Details furnished in any other format shall not be considered. <b>All the documents shall be furnished only in English. Documents furnished in other langauges will not be considered for further evaluation.</b>			
	(c) BHEL reserves the right to cross verify with the above such customers and satisfy itself with reference to the claims of the supplier. If the information furnished by the supplier is not found satisfactory/ no response from customer, the offer will be technically rejected.			

<b>S.S. Seamless U Tubes for High Pressure Feed Water Heater Application (contd..)</b>				
4	The vendors shall register with BHEL through online vendor registration portal available in BHEL website (www.bhel.com) and submit the application online against PMD D.PT.006. Copy of the same shall be submitted along with the offer. (Applicable for vendors who are not registered in BHEL -HPEP, R. C. Puram against the subject item PMD)".			
5	Offers without the requirement as above 3(a) & 3(b) will not be technically evaluated by BHEL. Further, no correspondence in this matter will be entertained.			
6	For making S.S. Seamless tubes, the mother hollows may be directly procured as raw material or can be made from a round bar by heater tube manufacturer (a) If the Heater tube manufacturer makes mother hollows in his premises by sourcing round bars, the round bar shall be sourced, from the following vendors. i) MUKAND, Mumbai ii) DEW, Germany iii) ITALFOND, Italy iv) VIRAJ Profiles Ltd, Mumbai (b) In case, the vendors are sourcing the mother hollows directly for making S.S. Seamless tubes, the mother hollows are to be sourced from the following vendors. i) SANYO, Japan ii) POSCO, South Korea iii) SANDVIK, Sweden/India iv) KOBE STEEL, Japan v) Nippon Steel and Sumikin Stainless Steel Corporation (NSSC), Japan (c) The mother hollows shall be produced by hot extrusion method. (d) Either the round bars for making mother hollows or the mother hollows shall be UT tested. If the tube manufacturer desires to source round bars or mother hollows from any other reputed source, they may give full details of the round bars or mother hollows manufacturerers facilities, like manufacturing and testing facilities, size ranges and the customers to whom they are supplying. BHEL reviews the credentials of such supplier, and may accept the proposal if it is satisfied technically. The decision of BHEL is final in this regard.			
7	The vendors should furnish the detailed process of manufacturing and testing procedures along with the offer.			
8	List of BHEL qualified bidders may be forwarded to BHEL's End Customer for their review and approval. The list finalized by BHEL's End Customer shall be final and binding.			
9	BHEL team may carry out vendor evaluation/assesment(incase of a new vendor)by a visit to vendor works for qualifying /rejecting the technical bid based on the findings of the visit.			
10	Vendors to submit their bid in 2- part system, i.e. Part-I shall consists of Pre-Qualification Criteria along with the required documnets and Techno-commercial bids and Part-II shall consists of Price Bid. Offers failing to meet prequalification part will not be considered for further evaluation.			

## High Pressure Feed water heater (HP Heater) Seamless tubes Reference details

Ref project S.no	Material (SA 213 TP 304 / SA 213 TP 304 N / SA 213 TP 304L/ SA 213 TP 304LN)	OD mm	THK (min 2.1) mm	Supply date DDMMYYYY	HP Heater Application (Yes/ No)	Heater manufacturer details			End customer details				
						Supplied to (Heater manufacturer's name)	Contact person	E-Mail id & Phone no	Name of the organisation(End user)	Project Details Name: MW Rating: Location	No.of years the equipment is in service	Contact person	E-Mail id& Phone no:
1													
2													
3													
4													
5													
6													

## Note:

- Reference list shall be submitted in the above format only.  
Vendors are requested to fill the above and submit along with PreQualification Criteria(PQC).Details mentioned above only are considered for PQC evaluation.
- wherever details are not available,vendor to mention as "NA"
- Reference project Tube material shall be SA213 TP 304/ SA 213 TP 304N/ SA 213 TP 304L/ SA213 TP 304 LN.Other tube material shall be considered as INVALID Reference.
- Reference project Tube OD shall be of 15.875mm(5/8 inch)only.Other tube shall be considered as INVALID Reference.
- Reference project Tube thickness shall be 2.1 mm minimum.Tube thickness less than 2.1 mm shall be considered as INVALID Reference.
- clause no 3(a) (i) to 3(a) (viii) of PQC must be combinedly met by the vendor against a single supply reference of U tubes.Maximum of 06 such reference shall be mentioned in the above table.

**SPECIAL CONTRACT CONDITIONS (SCC)  
FOR ENQUIRY NO. D3A1R78853 Dated 15.03.2018**

S. NO.	TERMS & CONDITIONS	BHEL REQUIREMENT	VENDOR 'S CONFIRMATION / REPLY																									
A	NAME & ADDRESS	Name, address, e-mail id, contact no.etc. of entity on whom order to be released in case of L <sub>1</sub> .																										
		The offer should be either from the manufacturer directly or from the authorised agency. In case of BHEL receiving offer from both, then offer from manufacturer will be considered and offer from agent shall be summarily rejected. <u>Note:</u> BHEL shall deal directly with all Indian manufacturers.																										
<b>I</b>	<b>TECHNICAL TERMS</b>																											
1	DESCRIPTION & SIZE	As per Enquiry																										
2	QUANTITY	<table border="1"> <thead> <tr> <th>Item no</th> <th>Material code</th> <th>1 Set</th> <th>Total Sets</th> <th>Total Quantity</th> </tr> </thead> <tbody> <tr> <td>1</td> <td>HE9718584471</td> <td>758</td> <td>4</td> <td>3032</td> </tr> <tr> <td>4</td> <td>HE9718583262</td> <td>1673</td> <td>4</td> <td>6692</td> </tr> <tr> <td>3</td> <td>HE9718583270</td> <td>1673</td> <td>4</td> <td>6692</td> </tr> <tr> <td>2</td> <td>HE9718583289</td> <td>1673</td> <td>4</td> <td>6692</td> </tr> </tbody> </table>	Item no	Material code	1 Set	Total Sets	Total Quantity	1	HE9718584471	758	4	3032	4	HE9718583262	1673	4	6692	3	HE9718583270	1673	4	6692	2	HE9718583289	1673	4	6692	
Item no	Material code	1 Set	Total Sets	Total Quantity																								
1	HE9718584471	758	4	3032																								
4	HE9718583262	1673	4	6692																								
3	HE9718583270	1673	4	6692																								
2	HE9718583289	1673	4	6692																								
3	SPECIFICATION	HE51173 Rev: 10																										
4	MATERIAL	SA213 TP304N as per ASME Sec - II Part - 'A' 2015 Edition and Addenda nil shall be followed for item no's.1 to 4.However,carbon contetn shall be limited to 0.05%.																										
5	DRAWING	(i)For Item No. 1: 4-175-01-03324 Rev: 00 (ii)For Item No. 2, 3 & 4: 3-175-01-02457 Rev: 00																										
6	QUALITY PLAN	HY/HE/010/SEAMLESS U - TUBES Rev: 04.																										
7	PACKING & MARKING	As per BHEL Standard AA0490003 Rev:02. Foreign vendors shall provide sea-worthy packing.																										
8	INSPECTION & CERTIFICATION	<b>Indian Vendors:</b> By BHEL TPIA/Customer as per Quality Plan and CIB in Form III B. <b>Note:</b> Vendors are advised to raise Inspection Call in CQIR system (www.cqir.bhel.in) with Purchasing Unit as 'HPEP' at least 3 working days prior to the proposed date of inspection.																										
		<b>Foreign Vendors:</b> By Lloyd's / TUV / BV / DNV (Overseas Inspection Agency)/Customer as per Quality Plan and in IBR Form III B. <b>(Note:</b> The above Inspection & Certification agencies shall be authorized / recognized / competent authority under Indian Boiler Regulations (IBR)1950 in the respective supplier's country).																										
<b>II</b>	<b>COMMERCIAL TERMS</b>																											
1	TERMS OF DELIVERY	FOR BHEL for Indian Vendors. CIP Mumbai basis for Foreign Vendors.																										
1A	FOR BHEL price / delivery implies (for Indian Suppliers)	a) Freight & Insurance are in vendor's scope and price quoted is inclusive of F & I. b) C-Note date or Date of submission of documents, whichever is later shall be considered as delivery date incase documents are not submitted within 10 days from the dispatch of the material.																										
1B	CIP Mumbai price / delivery implies (for Foreign Suppliers)	a) As per Incoterm. b) IGM date in bill of entry issued by customs shall be delivery date for the purpose of penalty.																										
		c) Exchange rate for Foreign Currency to INR shall be as per SBI Exchange rate (TT Seeling rate) as on Technical Bid Opening date. If the relevant day happens to be a bank holiday, then the forex rate as on the previous bank (SBI) working day shall be taken.																										
2	PACKING & FORWARDING CHARGES	P & F charges shall be inclusive in price.																										
3	FRIEGHT & INSURANCE	By supplier up to delivery point																										

S. NO.	TERMS & CONDITIONS	BHEL REQUIREMENT	VENDOR 'S CONFIRMATION / REPLY
4A	Third Party Inspection Charges	<p><b>Indian Vendors:</b> By BHEL and vendor's offer will be loaded by appropriate percentage for evaluation of offers. Currently it is 0.26%.</p> <p><b>Foreign Vendors:</b> Shall be inclusive in quoted price.</p>	
4B	CIB Charges / Certification in IBR Form - III B	<p><b>Indian Vendors:</b> Shall be inclusive in quoted price.</p> <p><b>Foreign Vendors:</b> Included in the scope of vendor for Overseas Inspection &amp; Certification Agency in IBR Form-III B as indicated at S.No. I(8).</p>	
5	DELIVERY	<p>(i) 2 Sets of Item No.1:- <b>4 months from PO date remaining in 8 months.</b></p> <p>(ii) 2 Sets of Item No.2:- <b>5 months from PO date remaining in 8 months.</b></p> <p>(iii) 2 Sets of Item No.3:- <b>6 months from PO date remaining in 9 months.</b></p> <p>(iv) 2 Sets of Item No.4:- <b>7 months from PO date remaining in 9 months.</b></p> <p><b>Note:</b> a)For delivery period longer than those indicated above, for each schedule quoted price of Item No.1, 2, 3 &amp; 4 shall be loaded by 0.5% per week during evaluation of offer. b)Delivery is critical for evaluation of offer. Offers with delivery period beyond one month grace period against the respective schedules are liable for rejection.</p>	<p>(i) ____ Months</p> <p>(ii) ____ Months</p> <p>(iii) ____ Months</p> <p>(iv) ____ Months</p>
6	SPLITTING OF QUANTITIES	Considering the large quantities & critical delivery requirement,BHEL may consider multiple sources of supply.Therefore,BHEL reserves the right to split or not split the total enquiry quantity.In case the need arises & BHEL decides to split the order/quantities,the same will be communicated along with manner of splitting to all eligible bidders,who qualify for splitting.	
7	END CUSTOMER APPROVAL	Bidders have to submit their credentials as per end customer formats enclosed as "Sub supplier questionnaire". Credentials of techno-commercially qualified bidders will be forwarded to end customer for their review and approval, inline with clause 8 of PQC. Price bids of techno-commercially qualified bidders will be opened, subjected to approval of customer.	
8	MSE CLAUSE	“MSE suppliers can avail the intended benefits only if they submit along with the offer, attested copies of either EM II certificate having deemed validity (Five years from the date of issue of acknowledgement in EM-II) or valid NSIC certificate or EM II certificate along with attested copy of a CA certificate (Format enclosed as per Annexure – III where deemed validity of EM-II certificate of five years has expired) applicable for the relevant financial year (latest audited). Date to be reckoned for determining the deemed validity will be the date of bid opening (Part-I). Non submission of such documents will lead to consideration of their bid at par with other bidders. No benefit shall be applicable for this enquiry if any deficiency in the above required documents are not submitted before price bid opening. If the tender is to be submitted through E-Procurement portal, then the above required documents are to be uploaded on the portal. Documents should be notarized or attested by a Gazetted Officer.”	

**SPECIAL CONTRACT CONDITIONS (SCC)  
FOR ENQUIRY NO. D3A1R78853 Dated 15.03.2018**

S. NO.	TERMS & CONDITIONS	BHEL REQUIREMENT	VENDOR 'S CONFIRMATION / REPLY
9	TWO-PART BID	<p>Your offer shall be submitted in two part bid system Part-1(i.e, Techno-Commercial bid&amp;Pre-qualification bid) and Part-2(price bid) separately in two sealed covers indicating our enquiry No. <b>D3A1R78853</b> date and tender due date clearly.</p> <p><b>Note:</b> Pre-Qualification Criteria are part of techno-commercial bid. BHEL prefers to evaluate Pre-Qualification Criteria of vendors first and rest of the techno-commercial bid subsequently. However, at its discretion BHEL may evaluate both Technical and Pre-Qualification Criteria simultaneously.</p>	
10A	TECHNO-COMMERCIAL BID	<p>Techno-Commercial Bid shall essentially consist of:</p> <ul style="list-style-type: none"> <li>(i) Duly filled in signed copy of Special Contract Conditions (SCC).</li> <li>(ii) Duly filled in signed copy of Instructions to Bidder (ITB).</li> <li>(iv) Duly filled in Pre-Qualification Criteria (PQC)</li> <li>(v) Details as per Annexure-1.</li> <li>(vi) Duly filled in Annexure-II (Non-Disclosure agreement)</li> <li>(vii) Documents /declarations in compliance with Annexure -A,B (if applicable).</li> <li>(viii) Signed copy of Priced Sheet without price.</li> <li>(ix) Filled in and signed Integrity Pact.</li> </ul> <p>All the above documents shall be duly authenticated by signature &amp; official stamp on each page.</p> <p><b>Note:</b> Bid shall be complete in all respects including all the documents / information required for techno-commercial evaluation. Incomplete offers shall be liable to rejection.</p>	
10B	PRICE BID	<p>Quoted price shall be on firm basis. Vendor shall quote prices strictly as per the pricing sheet enclosed.</p>	
11	REVERSE AUCTION	<p>BHEL reserves the right to go for Reverse Auction (RA) (Guidelines as available on www.bhel.com) instead of opening the sealed envelope price bid, submitted by the bidder. This will be decided after techno-commercial evaluation. Bidders to give their acceptance with the offer for participation in RA. Non-acceptance to participate in RA may result in nonconsideration of their bids, in case BHEL decides to go for RA.</p> <p>Those bidders who have given their acceptance to participate in Reverse Auction will have to necessarily submit 'Process compliance form' (to the designated service provider) as well as 'Online sealed bid' in the Reverse Auction. Non-submission of 'Process compliance form' or 'Online sealed bid' by the agreed bidder(s) will be considered as tampering of the tender process and will invite action by BHEL as per extant guidelines for suspension of business dealings with suppliers/ contractors (as available on www.bhel.com).</p> <p>The bidders have to necessarily submit online sealed bid less than or equal to their envelope sealed price bid already submitted to BHEL along with the offer. The envelope sealed price bid of successful L1 bidder in RA, if conducted, shall also be opened after RA and the order will be placed on lower of the two bids (RA closing price &amp; envelope sealed price) thus obtained. The bidder having submitted this offer specifically agrees to this condition and undertakes to execute the contract on thus awarded rates.</p> <p>If it is found that L1 bidder has quoted higher in online sealed bid in comparison to envelope sealed bid for any item(s), the bidder will be issued a warning letter to this effect. However, if the same bidder again defaults on this count in any subsequent tender in the unit, it will be considered as fraud and will invite action by BHEL as per extant guidelines for suspension of business dealings with suppliers/ contractors (as available on www.bhel.com).</p>	



**SPECIAL CONTRACT CONDITIONS (SCC)  
FOR ENQUIRY NO. D3A1R78853 Dated 15.03.2018**

S. NO.	TERMS & CONDITIONS	BHEL REQUIREMENT	VENDOR 'S CONFIRMATION / REPLY
		Details of vendor's Representative participating in RA like Name, E-mail, Phone and Fax No.	
12	EVALUATION OF OFFERS	The offers will be evaluated on individual item wise L <sub>1</sub> basis. The vendor shall quote <b>Rate per Set</b> basis for every item (details of set were mentioned in Pricing Sheet and also at S.No. I(2) above).	
13	GUARANTEE	Guarantee on the supplies for a period of 18 months from the date of dispatch or 12 months from the date of commissioning whichever is earlier.	
14	GUIDELINES REGARDING DEALINGS WITH INDIAN AGENTS OF FOREIGN SUPPLIERS	<p>It shall be incumbent on the Indian agent and the foreign principal to adhere to the relevant guidelines of Government of India, issued from time to time.</p> <p>The Agency Agreement should specify the precise relationship between the foreign OEM / foreign principal and their Indian agent and their mutual interest in the business. All services to be rendered by agent/ associate, whether of general nature or in relation to the particular contract, must be clearly stated by the foreign supplier/ Indian agent. Any payment, which the agent or associate receives in India or abroad from the OEM, whether as commission or as a general retainer fee should be brought on record in the Agreement and be made explicit in order to ensure compliance to laws of the country.</p> <p>Any agency commission to be paid by BHEL to the Indian agent shall be in Indian currency only.</p> <p>Tax deduction at source is applicable to the agency commission paid to the Indian agent as per the prevailing rules.</p> <p>In the absence of any agency agreement, BHEL shall not deal with any Indian agent (authorized representatives / associate / consultant, or by whatever name called) and shall deal directly with the foreign principal only for all correspondence and business purposes.</p> <p>The "Guidelines for Indian Agents of Foreign Suppliers" enclosed at annexure - 'A' shall apply in all such cases.</p> <p>The supply and execution of the Purchase Order (including indigenous supplies/ service) shall be in the scope of the OEM/ foreign principal. The OEM/ foreign principal should submit their offer inclusive of all indigenous supplies/ services and evaluation will be based on 'total cost to BHEL'. In case OEM/ foreign principal recommends placement of order(s) towards indigenous portion of supplies/ services on Indian supplier(s)/ agent on their behalf, the credentials/ capacity/ capability of the Indian supplier(s)/ agent to make the supplies/ services shall be checked by BHEL as per the extant guidelines, before opening of price bids. In this regard, details may be checked as per Annexure-B (copy enclosed). It will be the responsibility of the OEM/ foreign principal to get acquainted with the evaluation requirements of Indian supplier/ agent as per SEARP available on www.bhel.com.</p> <p>As per directives of CENTRAL VIGILANCE COMMISSION, GOVERNMENT OF INDIA, one agent can not represent two or more suppliers or quote on their behalf in a particular tender. If so found at any stage, BHEL Hyderabad is likely to cancel Enquiries / POs to such suppliers. Further, such Indian Agent is likely to be de-listed (Black listed for business from BHEL).</p>	

S. NO.	TERMS & CONDITIONS	BHEL REQUIREMENT	VENDOR 'S CONFIRMATION / REPLY
15	INTEGRITY PACT (IP)	<p>(a) IP is a tool to ensure that activities and transactions between the Company and its Bidders / Contractors are handled in a fair, transparent and corruption free manner. A panel of Independent External Monitors (IEMs) have been appointed to oversee implementation of IP in BHEL.</p> <p>The IP as enclosed with the tender is to be submitted (duly signed by authorized signatory who signs in the offer) along with techno-commercial bid. Only those bidders who have entered into such an IP with BHEL would be competent to participate in the bidding. In other words, entering into the Pact would be a preliminary qualification.</p> <p>Details of IEM for this tender is furnished below:</p> <p>Name: Shri D.R.S Chaudhary, IAS (Retd.) Address: Flat No. L-202 &amp; L-203 (1st Floor), Ansal Lake View Enclave, Shamla Hills, Bhopal- 462 013 (M.P.). E-mail: dilip.chaudhary@icloud.com</p>	
16	FINANCIAL STANDING	<p><b>Indian Bidders:</b> Vendor to submit annual Financial Turnover during the Past 3 Years along with copy of 3 years Audited Balance Sheet.</p>	
		<p><b>Foreign Bidders:</b> Vendor to submit copy of latest D&amp;B Report.</p>	
17	EARNEST MONEY DEPOSIT (EMD)	EMD charges not applicable for quoting against this tender.	
18	SOURCING OF ROUND BARS / MOTHER HOLLOWES	As indicated in S.No. 6 of Pre-Qualification Criteria, vendor may suggest sources of round bars / mother hollowes different from standard sources mentioned in the list. BHEL may or may not accept new sources suggested by vendor. However, there is no provision of revision of price for acceptance or non-acceptance of new sources after opening of Part-I Bid.	
19	TERMS & CONDITIONS	<p>Vendor is requested to furnish all details of the offer in this format. <b>In case of any discrepancy between information furnished here and those furnished elsewhere in the bid, the information furnished in this document only shall be considered, and those furnished else where shall be ignored.</b></p> <p>No announcements, press releases, handouts or photographs for publication etc. relating to this agreement/ purchase-order/ work-order or any part of the Supply/Work shall be issued or released without BHEL's prior written approval</p>	

( Attachment to Enquiry No. **D3A1R78853** Due on Date **05.04.2018** for submission by 11.00 hrs to open from 14.00 hrs.)

**INSTRUCTIONS TO BIDDER (ITB)**

**NOTE: Bidder to confirm in affirmative by typing "YES" or "Applicable Data" in the response column. Deviations , if any shall be recorded in deviations/comments column (Separate sheet can be attached if needed). Non deviatable clauses are indicated as "NON DEVIATABLE".**

S. No.	DETAILED TERMS & CONDITIONS	VENDOR RESPONSE (YES/NO)	DEVIATIONS / COMMENT		
<b>1</b>	<b>SCOPE OF SUPPLY:</b>				
	Signed & Sealed offers are invited for the Scope of Supply of goods and Services or both as detailed in the enquiry. Relevant enclosures/supporting documents / catalogue, if any shall be enclosed to the technical offer. Bidder can also submit offer through email at their own risk. The offer is to be submitted in two parts. Technical offer to be submitted to mail ID <a href="mailto:technicalbid_hyd@bhel.in">technicalbid_hyd@bhel.in</a> , and price bid to be submitted to mail ID <a href="mailto:pricebid_hyd@bhel.in">pricebid_hyd@bhel.in</a> as an attachment only. Interchanging the information in the mails may lead to rejection of the offer. Supplier shall have no claim on e-mail offers sent on any other e-mail ID. In case of e-mail offers, the mail subject should contain Enquiry No. Due date and Supplier name, Supplier address including contact details shall be mentioned in the content of the mail. Without these details offer is liable for rejection.				
<b>2</b>	<b>GENERAL INSTRUCTIONS:</b>				
<b>A</b>	The quotation should be neatly typed and free from over writing/ erasures. Any correction or addition must be authenticated. The offer including annexures and brochures should be submitted in English / Hindi. All Pages of Techno Commercial Bids (Main Pages), ITB should be signed and Stamped. If there is a conflict in case of bilingual submission, the submission in English will be final.				
<b>B</b>	In case of Single-Part bid Tender, the complete bid shall be submitted in a single sealed cover super subscribing the Tender number and due date. Incomplete offers are liable for rejection. E mail bids shall be sent to mail ID <a href="mailto:pricebid_hyd@bhel.in">pricebid_hyd@bhel.in</a> as an attachment only.				
<b>C</b>	Bidders to please note that the Terms & conditions contained in this document and Special conditions, if any, are to be read fully before submission of quotations.				
<b>D</b>	BHEL reserves the right to process the tender through Reverse Auction (RA) route. Bidders are requested to go through RA guidelines (which are attached) and confirm acceptance of the same. Otherwise the offer is liable for rejection. BHEL will decide (after technical bid opening), at its discretion, to process the tender through Reverse Auction or by opening price bids.				
<b>E</b>	Vendors are advised to comply with specific conditions of the enquiry, Should there be any deviations (where deviations are permitted), it shall be entered in the deviation column. BHEL reserves the right to reject such offers or load the bid suitably for evaluation.				
<b>F</b>	Offers shall be submitted directly, only by the vendor or by their authorized representative / agent and the offer should be in line with the regulatory guidelines (i.e A valid Agency agreement between principal vendor and agent / representative shall be attached and the agreement shall cover the scope of services rendered by Agent, Agency Commission and any other information called for as per the regulatory guidelines). OEM / Mill details shall be provided if supplier is not a manufacturer. Bid envelopes shall bear the name of Supplier. In case of submission through authorized representative/agent, the name of representative/agent should also be mentioned apart from supplier name.				
<b>G</b>	Offer received after the specified time and date of submission shall be rejected. No further correspondence shall be entertained.				
<b>H</b>	Unsolicited offers shall not be considered.				
<b>3</b>	<b>OTHER PARTICULARS (Please indicate applicable data)</b>				
<b>A</b>	Name of the Bid currency (freely tradable foreign currency for imports and Indian Rupees for indigenous purchase).				
<b>B</b>	Name of the Port of loading and Port of Discharge (applicable to imports).				
<b>4</b>	<b>BID SUBMISSION PROCEDURE:</b>				
<b>A.</b>	<b>For Single Part Bids:</b> Offers addressed to DGM/CMM, Vendor Complex, BHEL, Hyderabad must be sent in a sealed cover on which tender enquiry number and the due date shall be super subscribed and sent by appropriate mode to above address or dropped in tender box located at vendor complex on or before the specified time and date of submission of offers, preferably in the bidder's envelope. For e-mail offers please follow the procedure mentioned in 2 (B).				

( Attachment to Enquiry No. **D3A1R78853** Due on Date **05.04.2018** for submission by 11.00 hrs to open from 14.00 hrs.)

**INSTRUCTIONS TO BIDDER (ITB)**

S. No.	DETAILED TERMS & CONDITIONS	VENDOR RESPONSE (YES/NO)	DEVIATIONS / COMMENT
<b>B.</b>	<b>For two-Part Bids:</b>		
<b>i</b>	Two part bid consisting of i) Techno-commercial Bid - ( Part-I), with all technical specification & scope including bill of material etc., EMD (where applicable) and unpriced bid with all applicable Commercial Terms and Conditions, rates of agency commission, duties, taxes and other charges, <u>except the price</u> , super scribing enquiry No. (Techno-Commercial Bid) and due date. Signed and Stamped ITB and special conditions of contract, if any is required to be attached along with Techno-commercial Bid (i.e. Part-I). AND ii) Price Bid (Part-II), containing ONLY the price (including agency commission, if any) and the applicable duties / taxes / other charges shall be kept in a separate sealed cover super subscribing Enquiry no. (Price bid) & due date. Both these covers shall be kept in a Third cover super subscribing Enquiry no. & due date. All techno commercial terms & conditions mutually agreed prior to price bid opening shall prevail and supersede any terms and conditions specified otherwise in price bid.		<b>Non-Deviatable</b>
<b>ii</b>	Techno-commercial Bid will be opened on the assigned date. Only the price bids of vendors whose techno commercial bids are accepted will be opened later on a specified date. In case BHEL opts for Reverse Auction, the date of conducting RA will be intimated separately to all the qualified bidders.		<b>Non-Deviatable</b>
<b>iii</b>	The bidders whose bids are techno-commercially not accepted will be informed & EMD (Earnest Money Deposit) shall be returned wherever submitted.		
<b>iv</b>	Bidders will be allowed to submit the impact on their quoted prices due to changes in technical scope, specifications, and commercial terms / conditions as specified in NIT which in the opinion of BHEL warrant changes in prices.		<b>Non-Deviatable</b>
<b>v</b>	Bids shall be opened on due time and date in the presence of bidders who may like to be present. Only one representative of each bidder shall be permitted to attend the bid opening.		<b>Non-Deviatable</b>
<b>5</b>	<b>Delivery Instructions</b>		
<b>A.</b>	<u>Indigenous Purchase:</u>		
	Goods shall be delivered on FOR Destination basis to the named destination(s) or as specified in the enquiry, Insurance in the scope of supplier.		
<b>B.</b>	<u>Imports:</u>		
	The goods shall be delivered on CIP-basis to port of discharge as mentioned in the purchase order.		
<b>6</b>	<b>Documentation:</b>		
<b>A.</b>	<u>Indigenous Purchase</u>		
	Seller shall arrange to send to BHEL, Hyderabad along with all the required documents as detailed in Purchase Order, such as, <b>Tax Invoice (Original for Recipient, Duplicate for Transporter), consignee copy of LR, Packing list</b> , Pre-dispatch Inspection report, Test/ Guarantee/ Warranty certificate/ O&M manuals (as applicable) etc. immediately on dispatch of the goods. Any addition/ exclusion to such documents shall be as specified in the Purchase Order. In case of dispatches from vendor works to site, material receipt certified by site office / Customer shall be provided. Softcopies of the above documents shall be uploaded in Pradan portal <a href="https://web.bhelhyd.co.in/mm/">https://web.bhelhyd.co.in/mm/</a> immediately after dispatch of the material.		<b>Non-Deviatable</b>
<b>B</b>	<u>Imports</u>		
	(i) Seller shall inform the purchaser the readiness of material along with packing details well in 30 days advance from the date of delivery. Seller shall also upload soft copy of the dispatch documents consisting of BL / AWB, Invoice, Shipping list & Test certificates and other documents as specifically indicated in the Purchase Order in PRADAN Portal ( <a href="https://web.bhelhyd.co.in/mm/">https://web.bhelhyd.co.in/mm/</a> ) within 3 days from the B/L date for sea shipment and 1 day from AWB date for Air shipment.		
	(ii) In case of CIP shipments, seller shall also inform purchaser the information about discharge port agent details and ship arrival information within 7 working days from the date of Shipment.		

( Attachment to Enquiry No. **D3A1R78853** Due on Date **05.04.2018** for submission by 11.00 hrs to open from 14.00 hrs.)

**INSTRUCTIONS TO BIDDER (ITB)**

S. No.	DETAILED TERMS & CONDITIONS	VENDOR RESPONSE (YES/NO)	DEVIATIONS / COMMENT																		
	<p>(iii) In case the material shipped in Full Containers(FCL), Seller shall ensure that the Bill of Lading should clearly spell out the following:</p> <ol style="list-style-type: none"> <li>1. Port of discharge -- "Nhavaseva"/chennai</li> <li>2. Place of Delivery / Final Destination - "ICD Sanath Nagar".</li> <li>3. For air consignment the port of discharge will be Hyderabad, India and consignee shall be BHEL.</li> </ol>																				
	<p>(iv) In case of Air shipment, the following dimensions of single package may be noted:</p> <ol style="list-style-type: none"> <li>a) Dimension of the cargo(ODC) -- &gt; 125" x 88" x 63"</li> <li>b) Weight of the cargo --&gt;3.5 MT.</li> </ol> <p>If any package dimension or weight crosses the above set limits, it will be treated as Over Dimension Cargo (ODC) or Over Weight Cargo and seller shall inform BHEL well in advance of 20 days prior to the delivery date to enable BHEL to finalize the freight forwarder.</p>																				
	<p>(v) <u>Recovery charges for non-submission of documents :</u> Seller shall submit all the required documents to BHEL as prescribed in the Purchase order and NIT. If BHEL incurs any charges such as Penalty, demurrage, container detention, wharf age, storage, Ground rent etc., due to non - compliance / non - submission of documents prescribed in Purchase Order / Tender Document / Letter of credit , the same shall be recovered from the seller as under:</p> <p><b>1. EUROPE/USA/Black Sea/ Far East/Middle East/South East sector</b></p> <p>A. For EX-WORKS / FCA/ FAS / FOB Sea Consignments: Penalty for late submission / negotiation of documents beyond 14 days shall be as under:</p> <table border="1" style="width: 100%; border-collapse: collapse;"> <thead> <tr> <th rowspan="2">S.No.</th> <th rowspan="2">Period (From Date of Bill of Lading)</th> <th>Recoverable Charges</th> <th colspan="2">Recoverable Charges per day per</th> </tr> <tr> <th>LCL per week/ Break bulk cargo per day</th> <th>20FT Container</th> <th>40FT Container</th> </tr> </thead> <tbody> <tr> <td align="center">i</td> <td align="center">Upto 14th day</td> <td align="center">Nil</td> <td align="center">Nil</td> <td align="center">Nil</td> </tr> <tr> <td align="center">ii</td> <td align="center">15th day onward</td> <td align="center">USD 10</td> <td align="center">USD 50</td> <td align="center">USD 105</td> </tr> </tbody> </table> <p>B. For CIF / CFR / CIP / CPT Sea Shipments: Vendor shall provide rates for detention charges after free period at the time of offer itself in case of engagement of 20FT Container and 40FT category. In case of late presentation of documents to the bank recovery will be effected from the Vendor as per the rates quoted by the Vendor at the time of offer in this regard. In case of Break bulk cargo and LCL Demurrage/storage charges shall be recovered at rate of USD 10 per day and storage charges rate of USD 10 per week respectively shall be charged as late presentation charges.</p>	S.No.	Period (From Date of Bill of Lading)	Recoverable Charges	Recoverable Charges per day per		LCL per week/ Break bulk cargo per day	20FT Container	40FT Container	i	Upto 14th day	Nil	Nil	Nil	ii	15th day onward	USD 10	USD 50	USD 105		
S.No.	Period (From Date of Bill of Lading)			Recoverable Charges	Recoverable Charges per day per																
		LCL per week/ Break bulk cargo per day	20FT Container	40FT Container																	
i	Upto 14th day	Nil	Nil	Nil																	
ii	15th day onward	USD 10	USD 50	USD 105																	
	<p>(vi) Description of items in invoice, packing list, BL / AWB or LR shall be same as PO item description. Vendors shall ensure that invoice shall contain PAN nos. of both seller and buyer along with other tax related numbers. BHEL PAN AAACB4146P and BHEL TAN HYDB00086C. Any other additional documents sought by the statutory authorities, the same shall be produced by the seller on priority basis.</p>																				
	<p>(vii) Seller shall provide package details including number of packages, gross weight, net weight etc.</p>																				
	<p>(viii) The seller shall provide the following documents at the time of submission of offer :</p> <ol style="list-style-type: none"> <li>a) No Business Connection in India declaration issued by the seller as per the format specified. (or)</li> <li>b) (i) No Permanent Establishment in India declaration issued by the seller as per the format specified. (ii) Tax Residence Certificate issued by the seller's tax authorities. (iii) Form 10F issued by the supplier.</li> <li>c) In case the seller has a Business Connection in India as per Section 9 of Income Tax Act or Permanent Establishment in India as per Article 5 of Double Taxation Avoidance Agreement between India and the seller's country, the seller shall provide a withholding tax order issued by the Indian Income Tax authority for recovery of applicable tax.</li> </ol>																				

( Attachment to Enquiry No. **D3A1R78853** Due on Date **05.04.2018** for submission by 11.00 hrs to open from 14.00 hrs.)

**INSTRUCTIONS TO BIDDER (ITB)**

S. No.	DETAILED TERMS & CONDITIONS	VENDOR RESPONSE (YES/NO)	DEVIATIONS / COMMENT
<b>7</b>	<b>Delivery Schedule</b>		
<b>A</b>	The tendered goods shall be delivered within the period stipulated in PO. Delivery <b>at BHEL</b> can be accepted at the earliest, 30 days prior to delivery date as mentioned in the Purchase order. Delivery <b>earlier than</b> 30 days of contractual delivery date may be accepted with the written permission of BHEL -Purchase department. Goods arriving after the delivery date will be accepted only with the prior written permission of BHEL otherwise they will not be allowed inside the factory. BHEL reserves the right to reject the material, if not delivered by scheduled Purchase Order Delivery Date. (In case of imports , the final entry date of Import General Manifest (IGM) will be reckoned as delivery completion date )		<b>Non-Deviatable</b>
<b>B</b>	Documents such as TC,GCs Inspection reports are to be submitted within 10 days of dispatch of these materials. C note date or Date of submission of documents whichever is later shall be considered as delivery date incase documents are not submitted within 10 days from the dispatch of the material. Supply of plant/ equipment/ stores shall not be considered complete until they have been inspected and accepted at the place and destination specified for delivery by the time stipulated under the terms & conditions of the Order/ Contract. Mere payment by itself shall not constitute acceptance of the goods or materials in any manner, whatsoever.		
<b>8</b>	<b>Pricing Terms</b>		
	Prices once quoted shall remain firm and valid during the execution of PO. Offers with PVC will be rejected outright except in cases where specifically called for in the NIT.		<b>Non-Deviatable</b>
<b>9</b>	<b>PRICE VALIDITY :</b>		
	Unless otherwise specified, offer shall be valid for a period of 90 days from the date of bid opening (Technical bid /part-I in case of two part bid). However the prices quoted for spare parts of the Main equipment shall be kept valid for a period of 1 year from the date of Placement of PO for the main equipment.		
<b>10</b>	<b>Taxes &amp; Duties (RATE TO BE INDICATED by the bidder against the space provided )</b>		
<b>A.</b>	<b>Indigenous Purchase:</b> The Taxes as applicable shall be quoted in the following manner.		
<b>i</b>	<b>Vendor to indicate HSN of Goods or SAC of Services.</b>		
<b>ii</b>	<b>IGST/CGST/SGST/UTGST: Rate of Tax to be quoted as extra in %</b>		
	<b>NOTE:</b> Bidders to ensure correct applicability of <b>IGST/CGST/SGST/UTGST</b> based on the Inter / Intra state movement of goods. Taxes prevalent on the contractual delivery date or the actual delivery date (incase of delay) which ever is lower shall be applicable paid. <b>In case Bidder has opted for GST Composition Scheme, the same may be stated explicitly both in their technical and price bids.</b>		
<b>iii</b>	Any other taxes & duties not covered anywhere above may be indicated separately.		
<b>iv</b>	Taxes deducted at source: TDS as per the extant statute shall be recovered. In case vendor does not provide PAN details/concessional certificates, the TDS deduction shall be at the maximum percentage stipulated as per the provisions of Income Tax Act.		<b>Non-Deviatable</b>
<b>B.</b>	<b>Foreign Purchase (Imports):</b>		
<b>i</b>	The offered price shall be inclusive of all the Taxes and duties as applicable in country of bidder / country of dispatch for the quoted CIP price.		<b>Non-Deviatable</b>
<b>ii</b>	Taxes deducted at source: TDS as per the extant statute shall be recovered. In case vendor does not provide PAN details/concessional certificates, the TDS deduction shall be at the maximum percentage stipulated as per the provisions of Income Tax Act.		<b>Non-Deviatable</b>



( Attachment to Enquiry No. **D3A1R78853** Due on Date **05.04.2018** for submission by 11.00 hrs to open from 14.00 hrs.)

**INSTRUCTIONS TO BIDDER (ITB)**

S. No.	DETAILED TERMS & CONDITIONS	VENDOR RESPONSE (YES/NO)	DEVIATIONS / COMMENT
<b>11</b>	<b>Payment Terms: Unless otherwise specified in Special Conditions, following shall be the terms of Payment.</b>		
<b>A.</b>	<p><b>Indigenous:</b> 100% payment along with taxes, freight &amp; insurance will be made with in 75 days from the date of receipt of complete documentation as per PO. However payment would be done only after receipt of original documents, including site/ Customer acknowledgement on LR (MRC - Material Receipt Certificate at site) / GR clearance at BHEL Stores. For MSEs (covered under MSME Act) which are registered and periodically renewed with BHEL, this period will be 45 days* as prescribed in the relevant act. <b>Adherence to the above time schedule of payment is contingent upon Vendor complying with GST provisions and availment of Input Tax Credit by BHEL before the date of payment.</b> *The taxes that are reimbursed would be the ones applicable as on the contractual Purchase Order delivery date or the amount actually paid whichever is less. <b>In case GST credit is delayed/ denied to BHEL, due to non/delayed receipt of goods and/or tax invoice or expiry of timeline prescribed in GST Law for availing such ITC, or any other reason not attributable to BHEL, GST amount shall be recoverable from Vendor along with interest levied/ leviable on BHEL.</b></p>		
<b>B</b>	<p><b>Imports:</b> i) 100% payment (less Indian Agency Commission, if any) shall be paid <b>through “Usance Letter of Credit / Cash Against Documents (CAD) / Wire Transfer” with a credit period of 60 days.</b> ii) LC will be opened after successful completion of pre dispatch inspection prior to the scheduled / agreed delivery date <b>LC will be opened within 7 working days from the date of request.</b></p>		
<b>C</b>	<p><b>Note:</b> 1) No advance payment is acceptable. However, in exceptional/rare cases, BHEL at its discretion, may consider advance payment against Bank Guarantee valid up to receipt of material at BHEL for 110% of advance amount issued / confirmed by any of the BHEL consortium banks. 2) Wherever EMD (Earnest Money Deposit) is applicable, it may be noted that no interest will be paid on EMD and the EMD will be paid back to unsuccessful bidders within <b>fifteen days</b> after award of the contract. Successful bidder's EMD will be converted to SD (Security Deposit). <b>Tender Cost wherever applicable is not refundable.</b></p>		<b>Non-Deviatable</b>
<b>12</b>	<p><b>Penalty clause:</b> In the event of delay in supply of goods, penalty of 0.5% per week or part there of shall be levied on the undelivered portion subject to a maximum of 10% of the order value. <b>Penalty amount so determined along with applicable GST thereon shall be recovered.</b></p>		
<b>13</b>	<p><b>Excess materials</b> supplied beyond tolerance limit as specified in PO, will not be accounted for.</p>		<b>Non-Deviatable</b>
<b>14</b>	<p><b>Rejected materials</b>, if any, shall be collected by the vendor within 90 days of such communication to the vendor .Beyond 90 days a ground rent of 0.25 % of the value of the material per week will be levied for a maximum period of two weeks.. Beyond this period the supplier forfeits their right to the materials.</p>		<b>Non-Deviatable</b>

( Attachment to Enquiry No. **D3A1R78853** Due on Date **05.04.2018** for submission by 11.00 hrs to open from 14.00 hrs.)

**INSTRUCTIONS TO BIDDER (ITB)**

S. No.	DETAILED TERMS & CONDITIONS	VENDOR RESPONSE (YES/NO)	DEVIATIONS / COMMENT
15	<p><b>Guarantee / Warranty Period :</b> (Deviation to this clause is not acceptable.) Wherever required, and so provided in the specifications/Purchase Order, the seller shall guarantee that the goods supplied shall comply with the specifications laid down, for materials, workmanship and performance. If within the guarantee period, the delivery is found to be non-complaint, the seller shall on his own account, replace repair, or re-execute the delivery at Purchaser's discretion on the purchaser's first request or within the mutually agreed period, without prejudice to Purchaser's other legal rights. If the seller continues to default on their obligations, purchaser has the right to proceed to replace, repair or re-execute the order at the seller's expense, with or without help from third parties. Purchaser shall notify the seller of the exercise of this right in advance where ever possible.</p> <p>Unless otherwise specified, guarantee period shall be 12 months from the date of commissioning or 18 months from the date of supply/replacement whichever is earlier. For bought out packages which are intended to be incorporated in installations or systems the guarantee period shall not start until the time the installations or systems are commissioned, provided always that the period ends not later than 30 months after the date of supply of the goods.</p> <p><b>The guarantee period shall be extended by the period during which the goods are not in compliance. A guarantee period as described above shall apply afresh to replaced, repaired or re-executed parts of a delivery.</b></p>		<b>Non-Deviatable</b>
<p><i>NOTE: Deviations (Commercial as well as Technical) from the tender specifications and conditions are generally not acceptable. However, deviation if any, shall be brought out clearly with proper justification in the offer. The deviation, if considered by BHEL, shall be loaded for comparison, while evaluating the offer. If a bidder unconditionally withdraws any deviation before price bid opening, the same shall not be loaded. Loading criteria in respect of major commercial conditions where deviations if any are accepted shall be as per clause No.16. The Vendors may specifically note the following:</i></p>			
16	<b>Evaluation and Loading Criteria:</b>		
A	Evaluation of prices shall be done item-wise unless otherwise specified in the enquiry. Evaluation shall be on the basis of delivered cost, i.e. "total cost to BHEL" w.r.t the finalized technical scope and commercial conditions (after considering incidence of applicable taxes and duties and loading). For evaluation, exchange rate (TT selling rate of State Bank of India) as on the date of bid opening (Part-I, in case of two-part bids) shall be considered. If the relevant day happens to be a bank holiday, then the forex rate as on the previous bank (SBI) working day shall be taken.		
B	In case of foreign bidders, the quoted CIP price shall be loaded by the following factors to arrive at the Delivered Cost:		
	i	- Import duty as applicable at the time of Price/ Part-II bid opening.	
	ii	- Port handling/ clearing charges & inland freight <b>and insurance:</b> @ 5% of CIP value (10% for plates, pipes & structurals).	
	iii	<p><b>In other cases subject to acceptance by BHEL, loading for various factors (in addition to above) as the case may be will be done as follows:</b></p> <p><b>0.5% for unloading at Port of Destination</b> <b>Marine Freight 4% and Marine Insurance 1% (9% and 1% towards Freight and Insurance respectively for Plates, Pipes, Rounds &amp; Structurals)</b></p>	
C	Incase of Indigenous Bidders, Ex-works offers received (as against FOR Destination mentioned in enquiry) shall be loaded by 4% of Ex-works value (9% for plates, pipes, rounds & structurals) unless otherwise mentioned in enquiry.		
D	Deviated Penalty: Any loading on penalty clause shall be 10% or to the extent to which the vendor has opted for deviation.		
E	Deviated Payment Terms: Terms: In case BHEL considers any deviation in payment terms, the bids shall be loaded with 18% interest per annum to the extent of deviation.		
17	Procurement directly from the manufacturers/ suppliers shall be preferred. However, no agent shall be allowed to represent more than one manufacturer/ supplier in the same tender. Moreover, either the agent could bid on behalf of the manufacturer/ supplier or the manufacturer / supplier could bid directly but not both. In case bids are received from both from the manufacturer/ supplier and the agent, bid received from the agent shall be ignored.		
18	<b>RIGHT OF REJECTION /NON- PLACEMENT OF PO:</b> BHEL reserves the right to accept or reject any or all bid/s in full or part without assigning any reason whatsoever.		
19	<p><b>INTEGRITY PACT:</b></p> <p>Vendors shall have to enter into Integrity Pact with BHEL as per attachment - for order value of rupees five crores and above and shall be signed by the competent authority before the issue of purchase order, failing which vendor's offer will be rejected.</p>		



( Attachment to Enquiry No. **D3A1R78853** Due on Date **05.04.2018** for submission by 11.00 hrs to open from 14.00 hrs.)

**INSTRUCTIONS TO BIDDER (ITB)**

<b>20</b>	<b>Benefits earmarked for Purchase from Micro &amp; Small Enterprises (MSEs) – Indigenous Purchase</b>
<b>20 A</b>	Tender documents to the NSIC registered vendors (If registered for tendered items) shall be issued free of cost & no EMD wherever called for will be insisted upon. NSIC registered unit bidders shall submit along with bid relevant documents including valid NSIC certificate. Date to be reckoned for determining the deemed validity will be the last date of Technical bid submission. Non- submission of such document will lead to consideration of their bid, at par with other bidders and MSE status of such bidders shall be shifted to Non- MSE supplier till the supplier submit these documents.
<b>20 B</b>	In tender, participating MSEs quoting price within price band of L1+15% shall also be allowed to supply a portion of requirement by bringing down their price to L1 price in a situation where L1 price is from someone other than a MSE and such MSE shall be allowed to supply up to 20% of total tendered value. In case of more than one such MSE, the supply shall be shared proportionately. A quantum of 4% out of 20% quantity, so earmarked, will be reserved for MSE's owned by SC / ST entrepreneurs who submit their bid with relevant documents. applicable in case of item-level evaluation tenders.
<b>20 C</b>	If an enterprise falling under MSME category as defined in the Act, graduates to a higher category from its original category or beyond the purview of the Act, it shall continue to avail all non-tax benefits of its original category notified by the Ministry of Micro, Small and Medium Enterprise for a period of three years from the date of such graduation to the higher category.
<b>21</b>	For Claiming Payments <b>for goods</b> received at BHEL works / Site from Vendors' Works): a) Original of Invoice marked as ORIGINAL FOR RECIPIENT b) Duplicate of Invoice marked as DUPLICATE FOR TRANSPORTER c) Packing List - clearly showing number of packages, gross weight and net weight. d) Warranty/Guarantee certificates (If applicable as per PO terms) e) Insurance certificate f) Third Party Inspection Certificates. g) LR Copy signed & stamped by Site incharge / Customer for site deliveries) (For material received at BHEL payment will be made against GR for accepted quantity)
<b>22</b>	Inspection Measuring and Test Equipment (IMTE) whether used by the Seller / Contractor or sub-contractor shall be calibrated, maintained and controlled. Calibration shall be valid and IMTE maintained in sound condition during usage.
<b>23</b>	ISO-9001, ISO14001 and OHSAS 18001 shall be complied
<b>24</b>	Applicable Conditions :These General conditions of Contract for Purchase apply to all enquiries, tenders, request for quotations, orders and agreements concerning the supply of goods and the rendering of related services (hereinafter referred to as "deliverables") to Bharat Heavy Electricals Limited, Ramachandrapuram, Hyderabad (hereinafter referred to as "BHEL" or the Purchaser) or its projects/customers. Any deviations from or additions to these General conditions of contract for Purchase' require Purchaser's express written consent. The general terms of business or sale of the Seller shall not apply to Purchaser. Orders, agreements and amendments thereto shall be binding if made or confirmed by the Purchaser in writing. Only the Purchasing department of the Purchaser is authorized to issue the Purchase order or any amendment thereof.
<b>25</b>	Being PMD Vendor, if you are not quoting against this tender enquiry, please send your regret letter positively for our reference with valid reasons for not participating in the tender enquiry. Repeated lack of response on the part of bidder may lead to deletion such PMD vendor from BHEL's approved vendor list. Vendor shall ensure that PAN details are available/updated with BHEL, else vendor shall attach PAN details with enquiry failing which offer shall be liable for rejection.
<b>26</b>	Kindly quote your prices in figures and words both. In case of any discrepancy in value, the prices quoted in words shall be considered for evaluation and establishing L1 Status.
<b>27</b>	Any discount / revised offer / bids submitted by a bidder on its own shall be considered, provided it is received on or before the due date and time of offer / bid submission (Part-1). Conditional discounts shall not be considered for evaluation of tenders.
<b>28</b>	The bidder whose bid is technically not accepted will be informed & EMD wherever submitted shall be returned after finalization of contract. EMD shall be forfeited in the event of bidder opting out after tender opening.
<b>29</b>	In case of abnormal delays (beyond the maximum late delivery period as per Penalty clause) in supplies / defective supplies or non-fulfillment of any other terms and conditions given in Purchase Order, BHEL may cancel the Purchase Order in full or part thereof, and may also make the purchase of such material from elsewhere / equivalent market price at the risk and cost of the supplier. BHEL will take all reasonable steps to get the material from alternate source at optimum cost. If bidder does not agree to the above Risk Purchase Clause, BHEL reserves the right to reject the offer. Nonperformance of contract attracts penal provisions inline with BHEL's Suspension of Business dealings.
<b>30</b>	Any other terms and conditions of the bidder attached / referred against the tender enquiry will not be considered.

( Attachment to Enquiry No. **D3A1R78853** Due on Date **05.04.2018** for submission by 11.00 hrs to open from 14.00 hrs.)

**INSTRUCTIONS TO BIDDER (ITB)**

<b>31</b>	All drawings as also all patterns and tool supplied by BHEL or made at BHEL's expense are BHEL's property. These cannot be used or referred to any other party and must only be used in the execution of BHEL's orders.
<b>32</b>	Any amount payable by the consignor / supplier under any of the condition of this contract shall be liable to be adjusted against any amount payable to the consignor / supplier under any other work / contract awarded to him. This is without prejudice to any other action as may be deemed fit by BHEL.
<b>33</b>	The bids of the bidders who are on the banned list and also the bids of the bidders, who engage the services of the banned firms, shall be rejected. The list of firms banned by BHEL is available on BHEL web site <a href="http://www.bhel.com">www.bhel.com</a> .
<b>34</b>	Definitions
Throughout these conditions and in the specifications, the following terms shall have the meanings assigned to them, unless the subject matter or the context requires otherwise.	
<b>34 A</b>	'The P Purchaser' means BHEL-HPEP, Ramachandra puram, Hyderabad-502 032 of Bharat Heavy Electricals Limited (A Govt. of India Undertaking) incorporated under the companies Act having its registered office at BHEL House, Siri fort, New Delhi-110049, India and shall be deemed to include its successors and assigns. It may also be referred to as BHEL.
<b>34 B</b>	'The seller' means the persons, firm, company or organization on whom the Purchase order is placed and shall be deemed to include the seller's successors, representatives, heirs, executors and administrator as the case may be. It may also be referred to as Contractor, supplier or vendor.
<b>34 C</b>	'Contract' shall mean and include the Purchase order incorporating various documents viz., tender/offer, letter of intent/acceptance, the General Conditions of contract and special conditions of contract for Purchase, specifications, inspection/quality plan, schedule of prices and quantities, drawings, if any enclosed are to be provided by the Purchaser or his authorized nominee and the samples or patterns if any to be provided under the provision of the contract. In case of any inconsistency or contradiction between any of the documents, the order of precedence shall be Purchase Order, LOI / LOA followed by specific conditions, special conditions of contract and general conditions of contract for commercial conditions; and specific agreement on technical conditions, special technical conditions and general technical conditions, tender/ offer.
<b>35</b>	'Parties to the contract' shall mean the seller and the purchaser as named in the main body of the Purchase Order.
<b>36</b>	<b><u>Ordering and confirmation of order:</u></b> The seller shall send the order acceptance in Toto within one week from the date of LOI / Purchase order or such other period as specified/agreed by the Purchaser. Purchaser reserves the right to revoke the order placed if the order confirmation differs from the original order placed. Purchaser shall only be legally bound if agreed explicitly in writing to be in agreement with the deviation. The acceptance of deliverables or supplies by Purchaser as well as payments made in this regard shall not imply acceptance of any deviations. The Purchaser order will be deemed to have been accepted if no communication to the contrary is received within one week (or the time limit as specified /agreed by the Purchaser) from the date of P.O. Purchaser, is at liberty to send signed P.O. through electronic media such as e-mail and the receipt of which shall be treated as receipt of order.
<b>37</b>	<b><u>Execution:</u></b> The whole contract is to be executed in the most workman like manner, substantial and approved as per the contracted terms.
<b>38</b>	<b><u>Progress Report:</u></b> The seller shall render such report as to the progress of work and in such form as may be called for by the Purchaser from time to time. The submission and acceptance of such reports shall not prejudice the rights of the purchaser in any manner. Seller shall communicate to BHEL immediately, change of address, ownership, contact person(s), the mobile numbers and e-mail of the dealing person concerned. Milestones shall be periodically updated by vendor/subcontractor through PRADAN Portal ( <a href="https://web.bhelhyd.co.in/mm/">https://web.bhelhyd.co.in/mm/</a> ). <b>Non updation will adversely affect service rating of vendor performance.</b>

( Attachment to Enquiry No. **D3A1R78853** Due on Date **05.04.2018** for submission by 11.00 hrs to open from 14.00 hrs.)

**INSTRUCTIONS TO BIDDER (ITB)**

<b>39</b>	<b>Product information, Drawings and documents / Non-disclosure and Information Obligations:</b>
	<p>Drawings, technical documents or other technical information received by one party shall not without the consent of the other party, be used for any other purpose than that for which they were provided. They may not, without the consent of the submitting party, otherwise be used or copied, reproduced, transmitted or communicated to third parties. All information and data contained in general product documentation, whether in electronic or any other form, are confidential and binding only to the extent that they are by reference expressly included in the contract.</p> <p>The seller shall, as per agreed date/s but not later than the date of delivery, provide free of charge any information and/or drawings which are necessary to permit the Purchaser to erect, commission, operate and maintain the product. Such information and drawings shall be supplied in the number of copies agreed upon or at least three copies of each.</p> <p>All intellectual properties, including designs, drawings and product information etc. exchanged during the formation and execution of the contract shall continue to be the property of the submitting party.</p> <p>The seller shall provide Purchaser with all information pertaining to the delivery in so far as it could be of importance to Purchaser. The seller shall not reveal confidential information to its own employees not involved with the tender/contract and its execution and delivery or to third parties, unless Purchaser has agreed to this in writing beforehand. The seller shall not be entitled to use the Purchaser's name in advertisements and other commercial publications including website without prior written permission from Purchaser.</p> <p>In the event of violation of the confidentiality as agreed, BHEL will take legal action as deemed fit. Non disclosure agreement to be entered as per <b>Annexure- II</b> wherever applicable.</p>
<b>40</b>	<b>Inspection and Testing:</b>
<b>40 A</b>	<p>The goods and stores shall be manufactured by approved quality system and each part/component may be inspected and tested by the Purchaser prior to shipment and shall fully comply with relevant requirements of Purchaser.</p> <p>Purchaser has the right to inspect at any stage during manufacture/ delivery. In the event of rejection, Purchaser shall inform the seller accordingly and Purchaser shall be entitled to replacement or repair at his discretion or may proceed to terminate or cancel the agreement. All this, does not affect Purchaser's right to recover compensation.</p>
<b>40 B</b>	<p>Purchaser or his authorized representative shall be entitled at all reasonable times during execution to inspect, examine and test at the seller's premises the material and workmanship of all stores to be supplied under the contract, and if the part of the stores are being manufactured at other premises, the seller shall obtain for purchaser or his authorized representative permission to inspect, examine and test as if the said stores are being manufactured at the seller's premises. Such inspection, examination and testing, if made shall not release the seller from any obligation under the contract.</p> <p>For indigenous suppliers all costs related to first inspection request shall be borne by the purchaser and the cost of subsequent inspections due to non-readiness of material / rework / rejections shall be borne by the seller. In case of imports all inspection charges including third party inspections if any shall be borne by the seller. The cost of inspection staff/third party specified by the Purchaser shall be borne by seller unless otherwise specifically agreed. Whether the contract provides for tests on the premises of the seller or any of his sub-contractor/s, seller shall be responsible to provide such assistance, labor, materials, electricity, fuels, stores, apparatus, instruments as may be required and as may be reasonably demanded to carry out such tests efficiently.</p> <p>Cost of any type test or such other special tests shall be borne by the seller unless otherwise specifically agreed in the contract.</p> <p>The Seller shall give the authorized representative of the purchaser reasonable notice in writing of the date on and the place at which any stores will be ready for inspection / testing as provided in the Contract. Annexure - I may be strictly be complied with for the time lines. Any delay in submission of the documents by the vendor will not alter the delivery date.</p>
<b>41</b>	<b>Quality and Condition of the Deliverables:</b>
	The seller shall be responsible for compliance with applicable technical, safety, quality, environmental requirements and other regulations in relation to his products, packaging and raw and ancillary materials.
<b>42</b>	<b>Packaging and Dispatch:</b>
	<p>The seller shall package the deliverables safely and carefully and pack them suitably in all respects considering the peculiarity of the material for normal safe transport by sea/air/rail/road to its destination suitably protected against loss, damage, corrosion in transit and the effect or tropical salt laden atmosphere. The packages shall be provided with fixtures/hooks and sling marks as may be required for easy and safe handling by mechanical means. Special packaging conditions/ environmental conditions as defined in the enquiry shall be fully complied.</p> <p>Each package must be marked with consignee name, P.O. number Package No. gross weight &amp; net weight, dimensions (LxBxH) and seller's name. The packing shall allow for easy removal and checking of goods on receipt and comply with carrier's conditions of packing or established trade practices. Packing list of goods inside each package with P.O. item No. &amp; quantity must also be fixed securely outside the box to indicate the contents. If any consignment needs special handling instruction, the same shall be clearly marked with standard symbols/instructions. Hazardous material should be notified as such and their packing, transportation and other protection must confirm to relevant regulations.</p>

( Attachment to Enquiry No. **D3A1R78853** Due on Date **05.04.2018** for submission by 11.00 hrs to open from 14.00 hrs.)

**INSTRUCTIONS TO BIDDER (ITB)**

<b>43</b>	<b>Delivery:</b>
	<p>Except as otherwise indicated in the Purchase order, delivery shall be FOR (Destination) for indigenous orders and CIP for imported orders. The delivery date (s) or delivery period (s) as stipulated in the agreement shall be firm and binding and shall apply to the entire delivery for each P.O. item. Partial shipments may however, be permitted by the purchaser on prior intimation from the Seller.</p> <p>Unless specifically agreed otherwise, transit insurance coverage will only be within India for imported consignments by BHEL. Accordingly, the seller shall send an intimation to the Purchase officer/Manager giving Purchase Order No., shipping particulars, Invoice value etc., immediately on dispatch of goods.</p>
<b>44</b>	<b>Penalty:</b>
	<p>The time or period of delivery as stipulated in the schedule of delivery shall be deemed to be the essence of the contract. Should circumstances arise whereby the deadline for an agreed delivery date(s) or period(s) is expected to be exceeded, the seller shall inform Purchaser hereof without delay. If delay in delivery is caused by any of the circumstances mentioned in clause 52 (Force Majeure) or which are caused exclusively by the acts of Purchaser, the Purchaser shall extend the time for delivery by a period which is reasonable having regard to all the circumstances in the case.</p> <p>If the Seller delays beyond any agreed delivery date(s) or period(s), Purchaser shall levy penalty for such delay @ 0.5% per week (7 days) or part thereof on delayed portion of the order value subject to a maximum of 10% of the value of the Purchase Order. However, penalty for delayed delivery will be calculated on 100% of the purchase order value if the material supplied cannot be put to intended use.</p> <p>The penalty will be charged on the value of the purchase order excluding statutory levies, freight and insurance wherever not included in the price. <b>Penalty amount so determined along with applicable GST thereon shall be recovered.</b></p> <p>Imposition, recovery or settlement of this penalty shall not affect Purchaser's right to performance, compensation and termination of the agreement.</p> <p>For delay analysis, period referred in Annexure-I will be considered as standard time lines for various major activities.</p>
<b>45</b>	<b>Transfer of Ownership and Risk:</b>
	<p>The risk for the delivery remains with the seller until the goods are delivered at the agreed place. However ownership shall get transferred as per terms of purchase order in line with INCOTERMS.</p>
<b>46</b>	<b>Price, invoicing and payment:</b>
	<p>The agreed prices are fixed prices in the currency as specified in the Purchase Order. They shall include packing, forwarding , loading and carriage to the place specified by the purchaser and are exclusive of all applicable taxes, duties etc., except for those specifically agreed by the Purchaser. Invoices shall be submitted bearing the Purchase Order number &amp; date, item number/s and supporting documents as called for in the Purchaser order.</p> <p>The direct payments (including LC/documents through Bank on collection basis), shall be made by E-payment mode and not by cheque /bank drafts except in special circumstances. Vendors shall furnish the E-payment particulars in the prescribed formats duly authenticated by their respective Bankers, If not got registered earlier with the Buyer.</p> <p><b>Invoice has to be raised quoting HSN Code of Goods or Accounting Code of Services. Invoice should mention BHEL-HPEP-HYDERABAD GSTIN: 36AAACB4146P1ZG or GSTIN of BHEL Nodal Agency as mentioned in PO.</b></p>
	<p>Indian Agency commission if payable and so specified in the Purchase order shall be paid in Indian Rupees, considering the SBI TT selling exchange rate prevailing on the date of tender opening (part 1 in case of two part bid), after successful completion of the contract.</p> <p>If so stipulated in the order, the seller shall furnish, on receipt of the Purchase Order or along with order acknowledgement, the billing break-up of prices (BBU) for approval by the purchaser in respect of the major items/components going into the equipment. This BBU is required by the Purchaser for admitting the claims of the seller if part shipments are contemplated and also to facilitate custom clearance after payment of duties in case of imports.</p> <p>In case of delay in receipt of supporting document details, consequential demurrage/wharf age/detention charges shall be to the account of the seller.</p> <p>Payment does not imply in any respect whatsoever a waiver of Purchaser's right to performance of the agreement. Purchaser is entitled to set off claimable debts against claimable liabilities with the seller by means of a setoff Note.</p>
<b>47</b>	<b>Contract variations; Increase or decrease in the scope of supply:</b>
	<p>Purchaser may vary the contracted scope during execution due to exigencies of project requirement.</p> <p>If the seller is of the opinion that the variation has an effect on the agreed price or delivery period, Purchaser shall be informed of this immediately in writing along with technical details, and in the event of additional work, submit a quotation with regards to the price and period involved, as well as the effect this additional work will have on the other work to be performed by the seller. Provided, that if unit rates are available in the contract, the same shall be applied to such additional work. The seller shall not perform additional work before purchaser has issued written instructions/amendment to the purchase order to that effect. The work which the seller should have or could have anticipated in terms of delivering the service (s) and functionality (ies) as described in this agreement should be executed by the vendor without any price implication.</p>

( Attachment to Enquiry No. **D3A1R78853** Due on Date **05.04.2018** for submission by 11.00 hrs to open from 14.00 hrs.)

**INSTRUCTIONS TO BIDDER (ITB)**

<b>48</b>	<b>Short shipments/ warranty/guarantee replacements:</b>
	In case of any short shipment during initial supply which is subsequently dispatched by the seller or any guarantee / warranty replacements shall be dispatched on “DDP-Delivered duty paid BHEL stores” basis for imported items and “FOR-BHEL Stores / designated destination” basis for indigenous items. Taxes, if any paid by indigenous vendor for short supply, guarantee /warranty replacement, repair activity shall be to vendor’s account only. <b>Vendor has to raise a credit note for short supplied quantity as per GST provisions.</b>
<b>49</b>	<b>Rejection/Replacement:</b>
	The seller shall arrange replacement / repair under its obligation under the contract within one month from the date of intimation or mutually agreed period. The rejected goods shall be taken away by the seller and replaced on DDP/FOR-BHEL Stores/designated destination basis within such period. In the event of the seller’s failure to comply. Purchaser may take appropriate action including disposal of rejections, at the cost and risk of the seller. <b>Vendor has to raise a credit note for rejected quantity as per GST provisions.</b>
	In case defects attributable to seller are detected during processing of the goods at purchaser’s / his subcontractor works, the seller shall be responsible for replacement /repair of the goods as required by the purchaser at seller’s cost.
<b>50</b>	<b>Export Administration Regulations:</b>
	If a delivery includes such technology and / or supply that is subjected to the export regulations the seller shall obtain due permissions, approvals, license etc.
<b>51</b>	<b>Cancellation / Termination of Contract and Risk Purchase:</b>
	Purchaser shall have the right to completely or partially terminate the agreement by means of written notice to that effect without prejudicing their other rights in the event that : <ul style="list-style-type: none"> <li>- The seller is declared bankrupt, its business has been shut down or liquidated, a substantial part of its assets have been attached/destroyed, or the business has been transferred to a third party.</li> <li>- Any misrepresentation or hiding of material fact if detected at a later stage.</li> <li>- The delivery is rejected after inspection or re-inspection.</li> <li>- In the event of termination, the risk of the items already delivered but not of use to Purchaser, as determined by purchaser, remains with the seller. The items shall then be at the seller’s disposal and they are to be collected by the seller. The seller shall refund any payments made by purchaser in terms of the terminated agreement immediately, not later than 30 days.</li> <li>- In the event of Cancellation/ termination of contract, BHEL reserves the right to procure the items which are not delivered as per PO and charge the excess cost from the defaulting seller. Incase the excess cost is not repaid by or recovered from the defaulting seller within 30 days, apart from legal recourse for effecting such recoveries, Penal action in line with BHEL’s Suspension of Business dealings will be taken.</li> </ul>
<b>52</b>	<b>Force Majeure</b>
	The supplier shall not be considered in default if delay occurs due to causes beyond their control such as Acts of God, Natural calamities, Fire, Frost, Flood, Civil War, civil commotion, riot, Government Restrictions. Only those causes that have duration of more than seven days shall be considered cause of force majeure. Notification to this effect duly certified by local chamber of commerce / statutory authorities with supporting documents shall be given by the supplier to BHEL by registered letter/courier service immediately without loss of time. In the event of delay due to such causes the delivery schedule shall be extended for a length of time equal to the period of Force Majeure or at the option of BHEL the order may be cancelled. Such cancellation would be without any liability whatsoever on the part of BHEL. In the event of such cancellation the supplier shall refund any amount advanced or paid to the supplier by BHEL and deliver back any material issued to him by BHEL and release facilities, if any provided by BHEL.
<b>53</b>	<b>Non-waiver of Defaults</b>
	If any individual provision of the contract is invalid, the other provisions shall not be affected.
<b>54</b>	<b>Settlement of Disputes</b>
	Except as otherwise specifically provided in the contract, all disputes concerning questions of the facts arising under the contract, shall be decided by the Purchaser, subject to written appeal by the seller to the purchaser, whose decision shall be final.
	Any disputes of differences shall to the extent possible be settled amicably between the parties thereto, failing which the disputed issues shall be settled through arbitration.
	The seller shall continue to perform the contract, pending settlement of disputes(s).



( Attachment to Enquiry No. **D3A1R78853** Due on Date **05.04.2018** for submission by 11.00 hrs to open from 14.00 hrs.)

**INSTRUCTIONS TO BIDDER (ITB)**

<b>55</b>	<p><b>Arbitration &amp; conciliation clause and Interest clause:</b></p> <p>(1) Except as provided elsewhere in this contract, in case amicable settlement is not reached between the parties, in respect of any dispute or difference; arising out of the formation, breach, termination, validity or execution of the contract; or, the respective rights and liabilities of the parties; or, in relation to interpretation of any provision of the contract; or, in any manner touching upon the contract, then, either party may, by a notice in writing to the other party refer such dispute or difference to the sole arbitration of an arbitrator appointed by head of the BHEL unit issuing the contract.</p> <p>The Arbitrator shall pass a reasoned award and the award of the Arbitrator shall be final and binding upon the parties.</p> <p>Subject as aforesaid, the provisions of Arbitration and Conciliation Act 1996 (India) or statutory modifications or re-enactments thereof and the rules made thereunder and for the time being in force shall apply to the arbitration proceedings under this clause, the seat of arbitration shall be at Hyderabad.</p> <p>The cost of arbitration shall be borne as per the award of the Arbitrator.</p> <p>Subject to the arbitration in terms of clause 55, the courts at Sangareddy, Telangana State shall have exclusive jurisdiction over any matter arising out of or in connection with this contract.</p> <p>Notwithstanding the existence or any dispute or differences and / or reference for the arbitration, the contractor shall proceed with and continue without hindrance the performance of its obligations under this contract with due diligence and expedition in a professional manner except where the contract has been terminated by either party in terms of this contract.</p> <p><b>In case of contract with Public Sector Enterprise (PSE) or a Government Department, the following shall be applicable:</b></p> <p>In the event of any dispute or difference relating to the interpretation and application of the provisions of the contract, such dispute or difference shall be referred by either party for arbitration to the sole arbitrator in the Department of Public Enterprises to be nominated by the secretary to the Government of India in-charge of the Department of Public Enterprises. The Arbitration and Conciliation Act, 1996 shall not be applicable to arbitration under this clause. The award of the arbitrator shall be binding upon the parties to the dispute, provided, however, any party aggrieved by such award may make further reference for setting aside or revision of the award to the Law Secretary, Department of Legal Affairs, Ministry of Law and justice, Government of India. Upon such reference the dispute shall be decided by the Law secretary or the special Secretary or Additional secretary when so authorized by the Law secretary, whose decision shall bind the parties hereto finally and conclusively. The parties to the dispute will share equally the cost of arbitration as intimated by the arbitrator.</p> <p>(2) INTEREST CLAUSE:</p> <p>In order to bring uniformity in all the contracts / agreements entered between BHEL and its contractors / vendors / suppliers / service providers etc., it is hereby advised to incorporate the following clause in all tenders and agreements.</p> <p>“No interest shall be payable by BHEL on earnest money or security deposit or any money due to the contractor by BHEL.”</p>
<b>56</b>	<b>Applicable Laws and jurisdiction of Courts</b>
	This agreement shall be construed and interpreted in accordance with the laws of India and shall have exclusive jurisdiction of Sangareddy/Hyderabad courts, Telangana, India.
<b>57</b>	<b>BHEL-Fraud prevention policy shall be adhered to.</b>
	The Bidder along with its associate/ Collaborators/ Sub-contractors/ sub-vendors/ consultants/ service providers shall strictly adhere to BHEL Fraud Prevention policy displayed on BHEL Website <a href="http://www.bhel.com">http://www.bhel.com</a> and shall immediately bring to the notice of BHEL management about any fraud or suspected fraud as soon as it comes to their notice.
	Fraud prevention policy and list of nodal officers is hosted on BHEL Hyderabad website <a href="http://web.bhelhyd.co.in">web.bhelhyd.co.in</a> .
Note: Purchase officer has to fill Annexure-I while sending enquiry	

Enquiry No: D3A1R78853  
Dated: 15.03.2018

**PRICING SHEET**

S. No.	Material Code	Description	Drawing No	OD (mm)	Leg Length (mm)	No. of Tubes per Set	Total No. of Sets	Total No. of Tubes	Currency (Rs., US\$, EURO etc)	Rate / Set	
										In Figures	In Words
1	HE9718584471	SS Seamless U Tubes	4-175-01-03324 Rev: 00	15.875	4600	758	4	3032			
2	HE9718583262	SS Seamless U Tubes	3-175-01-02457 Rev: 00	15.875	9800	1673	4	6692			
3	HE9718583270	SS Seamless U Tubes	3-175-01-02457 Rev: 00	15.875	11300	1673	4	6692			
4	HE9718583289	SS Seamless U Tubes	3-175-01-02457 Rev: 00	15.875	8700	1673	4	6692			
<p><b>NOTE:</b>  1) This format <b>without Price</b> shall be sent along with Technical Bid.  2) Indian bidders to quote Rate / Set on FOR BHEL basis.  3) Foreign bidders to quote Rate / Set on CIP Mumbai basis.  4) In case of any discrepancy in value, the prices quoted in words shall be considered for evaluation and establishing L<sub>1</sub> Status.</p>											
<p><b>Vendor Signature:</b></p>											
<p><b>Date:</b></p>											
<p><b>Seal:</b></p>											

FIRST ANGLE PROJECTION

(ALL DIMENSIONS ARE IN mm)

DRG. NO. 3-175-01-02457

H.P.HEATER-7A/7B	H.P.HEATER-8A/8B	H.P.HEATER-9A/9B
L = 9800	L = 11300	L = 8700
d = 15.875	d = 15.875	d = 15.875
MATERIAL CODE HE 9718583262	MATERIAL CODE HE 9718583270	MATERIAL CODE HE 9718583289

SL.NO.	RADIUS "R"	LEG LENGTH	H.P.HEATER NO. 7A/7B			H.P.HEATER NO. 8A/8B			H.P.HEATER NO. 9A/9B					
			THK	QTY.	DEV. LENGTH	THK	QTY.	DEV. LENGTH	THK	QTY.	DEV. LENGTH			
1	31.7	L	2.4 MIN	56	19700	2.5 MIN	56	22700	2.6 MIN	56	17500			
2	49.6	L	2.4 MIN	58	19756	2.5 MIN	58	22756	2.6 MIN	58	17556			
3	67.5	L	2.4 MIN	61	19812	2.5 MIN	61	22812	2.6 MIN	61	17612			
4	85.4	L	2.4 MIN	60	19868	2.5 MIN	60	22868	2.4 MIN	60	17668			
5	103.2	L	2.4 MIN	61	19924	2.5 MIN	61	22924	2.4 MIN	61	17724			
6	121.1	L	2.4 MIN	62	19980	2.5 MIN	62	22980	2.4 MIN	62	17780			
7	139.0	L	2.2 MIN	59	20037	2.5 MIN	59	23037	2.4 MIN	59	17837			
8	156.9	L	2.2 MIN	58	20093	2.5 MIN	58	23093	2.4 MIN	58	17893			
9	174.7	L	2.2 MIN	59	20149	2.3 MIN	59	23149	2.4 MIN	59	17949			
10	192.6	L	2.2 MIN	60	20205	2.3 MIN	60	23205	2.4 MIN	60	18005			
11	210.5	L	2.2 MIN	59	20261	2.3 MIN	59	23261	2.4 MIN	59	18061			
12	228.4	L	2.2 MIN	58	20318	2.3 MIN	58	23318	2.4 MIN	58	18118			
13	246.2	L	2.2 MIN	59	20373	2.3 MIN	59	23373	2.4 MIN	59	18173			
14	264.1	L	2.2 MIN	58	20430	2.3 MIN	58	23430	2.4 MIN	58	18230			
15	282.0	L	2.2 MIN	57	20486	2.3 MIN	57	23486	2.4 MIN	57	18286			
16	299.9	L	2.2 MIN	56	20542	2.3 MIN	56	23542	2.4 MIN	56	18342			
17	317.7	L	2.2 MIN	55	20598	2.3 MIN	55	23598	2.4 MIN	55	18398			
18	335.6	L	2.2 MIN	54	20654	2.3 MIN	54	23654	2.4 MIN	54	18454			
19	353.5	L	2.2 MIN	53	20711	2.3 MIN	53	23711	2.4 MIN	53	18511			
20	371.4	L	2.2 MIN	52	20767	2.3 MIN	52	23767	2.4 MIN	52	18567			
21	389.2	L	2.2 MIN	47	20823	2.3 MIN	47	23823	2.4 MIN	47	18623			
22	407.1	L	2.2 MIN	48	20879	2.3 MIN	48	23879	2.4 MIN	48	18679			
23	425.0	L	2.2 MIN	47	20935	2.3 MIN	47	23935	2.4 MIN	47	18735			
24	443.0	L	2.2 MIN	46	20991	2.3 MIN	46	23991	2.4 MIN	46	18791			
25	460.7	L	2.2 MIN	45	21047	2.3 MIN	45	24047	2.4 MIN	45	18847			
26	478.6	L	2.2 MIN	42	21104	2.3 MIN	42	24104	2.4 MIN	42	18904			
27	496.5	L	2.2 MIN	41	21160	2.3 MIN	41	24160	2.4 MIN	41	18960			
28	514.4	L+6	2.2 MIN	38	21216	2.3 MIN	38	24216	2.4 MIN	38	19016			
29	532.2	L+12	2.2 MIN	35	21272	2.3 MIN	35	24272	2.4 MIN	35	19072			
30	550.1	L+18	2.2 MIN	34	21328	2.3 MIN	34	24328	2.4 MIN	34	19128			
31	568.0	L+24	2.2 MIN	31	21384	2.3 MIN	31	24384	2.4 MIN	31	19184			
32	585.9	L+30	2.2 MIN	26	21441	2.3 MIN	26	24441	2.4 MIN	26	19241			
33	603.8	L+36	2.2 MIN	22	21497	2.3 MIN	22	24497	2.4 MIN	22	19297			
34	621.7	L+42	2.2 MIN	16	21553	2.3 MIN	16	24553	2.4 MIN	16	19353			
<b>TOTAL / HEATER</b>				<b>1673U</b>			<b>1673U</b>			<b>1673U</b>				
TOTAL DEVELOPED LENGTH IN METER FOR TUBE BUNDLE /HEATER			2.4 MIN	7103.82	2.5 MIN	10876.37	2.6 MIN	3072.56	2.2 MIN	27198.74	2.3 MIN	28445.18	2.4 MIN	27549.4
ESTIMATED WEIGHT OF TOTAL NUMBER OF TUBES PER HEATER IN Kgs./HEATER				~27856		~33260		~26500						

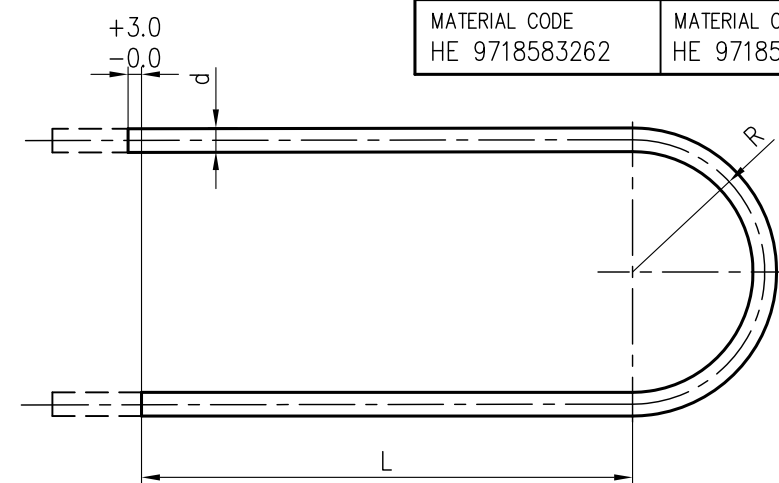

NOTES:-

- MATERIAL SA 213 TP 304N WITH CARBON MAX. 0.05% AS PER ASME SEC - II PART - A, YEAR OF EDITION AND ADDENDA AS PER P.O/ INDENT.
- TECHNICAL REQUIREMENTS AS PER PRODUCT STANDARD HE 51173 REVISION LATEST AS PER P.O/INDENT AND AS PER MATL. SPECIFICATION.
- QUALITY REQUIREMENTS INSPECTION & CERTIFICATION AS PER QUALITY PLAN :- HY/ HE/ 010/SEAMLESS U-TUBES REVISION LATEST AS PER P.O/INDENT.
- INSPECTION :- AS PER P.O/INDENT
- HYDRO TEST PRESSURE ON EACH TUBE = 585 Kg/sq.cm (g)
- a) MINIMUM WALL THICKNESS = +20% .  
-0%
- a) MAXIMUM WORKING PRESSURE (DESIGN PRESSURE) : 390 Kg/sq.cm (g)  
b) MAXIMUM WORKING TEMP. (DESIGN TEMP.) : 335 °C  
c) OPERATING MEDIUM : SHELL SIDE - STEAM & DRAIN.  
TUBE SIDE - FEED WATER.

INVENTORY NO. SIGN. AND DATE REF. DRG. NO. THE INFORMATION ON THIS DOCUMENT IS THE PROPERTY OF BHARAT HEAVY ELECTRICALS LIMITED. IT MUST NOT BE USED DIRECTLY OR INDIRECTLY IN ANY WAY DETRIMENTAL TO THE INTEREST OF THE COMPANY

TYPE OF PRODUCT OR NAME OF CUSTOMER/PROJECT **2X660MW MAITREE BANGLADESH**

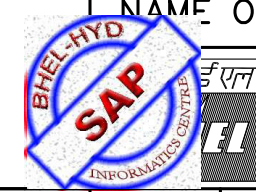

**BHARAT HEAVY ELECTRICALS LTD. HYDERABAD**

DRN.	NAME C.N.SAGAR	SIGN.	DATE 16.11.17	NO.OF VAR.
CHD.	A K SAHOO	AKS	16.11.17	NA
APPD.	K.KISHORE	KKK	16.11.17	

REV.	DATE	ALTERED	CHECKED	APPD.	REV.	DATE	ALTERED	CHECKED	APPD.	REV.	DATE	ALTERED	CHECKED	APPD.

DEPT. HEE	GRADE OF TOL.DIM. C/M/F	SCALE NTS	WEIGHT (KG) NA	REF. TO ASSY DRG. NA	ITEM NO. NA	NO.OF ITEMS NA
CODE 405						
TITLE <b>U - TUBE FOR H.P HEATER - 7A/7B,8A/8B &amp; 9A/9B</b>			CARD CODE	DRAWING NO. <b>3-175-01-02457</b>		REV. 00
			SHEET No. 1		NO OF SHEETS 1	



THE INFORMATION ON THIS DOCUMENT IS THE PROPERTY OF BHARAT HEAVY ELECTRICALS LIMITED. IT MUST NOT BE USED DIRECTLY OR INDIRECTLY IN ANY WAY DETRIMENTAL TO THE INTEREST OF THE COMPANY

REV.	DATE	ALTERED	CHECKED	APPD	REV.	DATE	ALTERED	CHECKED	APPD	ADDITIONAL INFORMATION
										STATUS OF DRAWING
										DISTURIBUTION OF PRINTS

SL.NO	RADIUS "R"	LEG LENGTH	DS HP HEATER NO. 6A/6B		
			THK	QTY.	DEV.LENGTH
1	31.7	L	2.7 MIN	47	9300
2	50.3	L	2.7 MIN	48	9359
3	68.9	L	2.5 MIN	49	9417
4	87.4	L	2.5 MIN	48	9475
5	106.0	L	2.5 MIN	47	9534
6	124.6	L	2.5 MIN	48	9592
7	143.1	L	2.5 MIN	47	9650
8	161.7	L	2.5 MIN	46	9708
9	180.2	L+6	2.5 MIN	45	9779
10	198.8	L+12	2.5 MIN	44	9849
11	217.3	L+18	2.5 MIN	45	9919
12	235.9	L+24	2.5 MIN	44	9990
13	254.5	L+30	2.5 MIN	43	10060
14	273.0	L+36	2.5 MIN	42	10130
15	291.6	L+42	2.5 MIN	41	10201
16	310.1	L+48	2.5 MIN	38	10271
17	328.7	L+54	2.5 MIN	36	10341
<b>TOTAL / HEATER</b>			<b>758 U</b>		
TOTAL DEVELOPED LENGTH IN METER			2.70 MIN	886.332	
FOR TUBE BUNDLE /HEATER			2.50 MIN	6523.046	
ESTIMATED WEIGHT OF TOTAL NUMBER OF TUBES PER HEATER IN Kgs./HEATER			~6625		
AVERAGE WEIGHT PER TUBE ( KG )			~8.74		

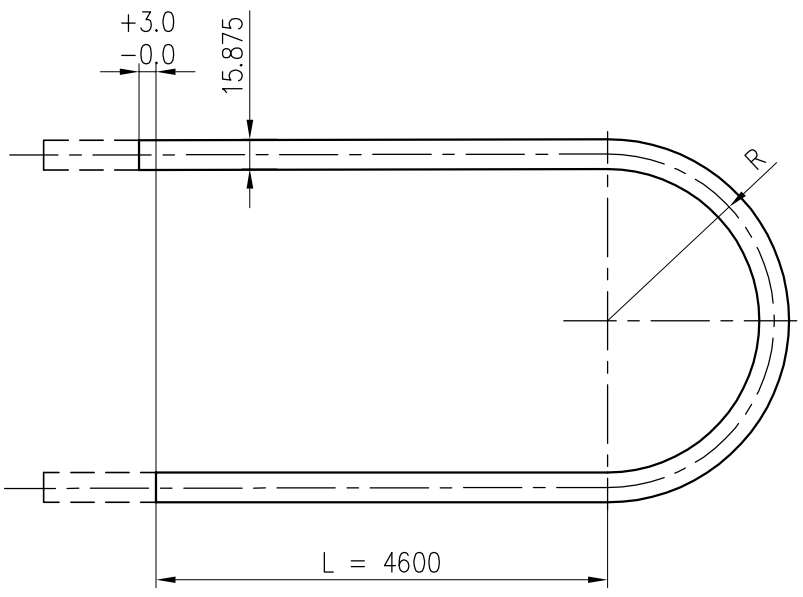

**NOTES: -**

- MATERIAL SA 213 TP 304N WITH CARBON MAX. 0.05% AS PER ASME SEC - II PART - A, YEAR OF EDITION AND ADDENDA AS PER P.O/ INDENT.
- TECHINICAL REQUIREMENTS AS PER PRODUCT STANDARD HE 5 1173 REVISION LATEST AS PER P.O/INDENT AND AS PER MATL. SPECIFICATION.
- QUALITY REQUIREMENTS INSPECTION & CERTIFICATION AS PER QUALITY PLAN : HY/ HE/ 010/SEAMLESS U-TUBES REVISION LATEST AS PER P.O/INDENT.
- INSPECTION :- AS PER P.O/INDENT
- HYDRO TEST PRESSURE ON EACH TUBE = 585 Kg/sq.cm (g)
- a) MINIMUM WALL THICKNESS = +20% .  
-0%
- a) MAXIMUM WORKING PRESSURE (DESIGN PRESSURE) : 390 Kg/sq.cm (g)  
b) MAXIMUM WORKING TEMP. (DESIGN TEMP.) : 355 °C  
c) OPERATING MEDIUM : SHELL SIDE - STEAM  
TUBE SIDE - FEED WATER.
- MATERIAL CODE - HE9718584471

ITEM NO	DESCRIPTION	DRAWING NO.	MATL. CODE	UNIT Wt.
			MATL. SPEN.	QTY.

	<b>BHARAT HEAVY ELECTRICALS LTD.</b> HYDERABAD		DRN.	NAME	SIGN.	DATE	NO.OF
			CHD.	S. BHATTACHARYA	S. BHATTACHARYA	06.02.2018	VAR.
			APPD.	AK SAHOO	<i>AK</i>	06.02.2018	NA
DEPT. HED	GRADE OF TOL.DIM. C/M/F	SCALE NTS	WEIGHT (KG) NA	REF. TO ASSY DRG. NA	ITEM NO. NA	NO.OF ITEMS NA	
CODE 405							
TITLE U-TUBE (DESUPERHEATER OF HPH 7A/7B)			CARD CODE	DRAWING NO. 4-175-01-03324		REV. 00	
				SHEET NO. 1	NO OF SHEETS 1		



# CORPORATE STANDARD

AA 049 00 03

Rev. No. 02

PAGE 1 OF 4

## PRESERVATION, PACKING AND MARKING OF U-BENT HEAT EXCHANGER TUBES

### 1.0 SCOPE:

This standard stipulates the requirements preservation, packing and marking of ferrous and non ferrous U-Bent heat exchanger tubes.

### 2.0 PRESERVATION:

#### 2.1 End Caps/Guides:

All the tubes shall be provided with plastic end caps of conical shape on both ends, in order to avoid ingress of water and other foreign matter.

A typical figure of the plastic cap is shown in the fig 3 for guidance.

#### 2.2 Rust prevention:

All carbon steel tubes shall be applied with suitable temporary rust preventive on the outer surface of the tubes, and required quantity of rust inhibitive powder shall be inserted inside the tubes before end capping.

### 3.0 PACKING:

#### 3.1 All tubes shall be packed and blocked in such a manner as to prevent damage in ordinary handling and transportation.

The boxes shall be constructed in such a manner that no nails, staples, screws or similar fasteners are required to close and secure the box after the tubes have been placed in the box. The box shall be lined with plastic sheet or vapour barrier materials so as to prevent chloride contamination of the tubes during handling, transportation and storage. The bottom of the case shall be rigid to enable the tubes to maintain straightness. Special lifting tackles, including beams, wherever necessary shall be provided with each case to avoid damage during transit. The U- bent tubes shall be arranged in boxes so that the smaller radius bends may be removed without disturbing larger radius bends. Tubes for each heat exchanger shall be boxed together.

A suitable amount of desiccant such as silica gel shall be placed in each packing box.

#### 3.2 Each package shall be of convenient weight for ease in handling. The weights shall not exceed 2000 Kg (Gross).

#### 3.3 Plastic/ nylon support guides as shown in fig.2 shall be placed in between the tubes in order to prevent rubbing of tube to tube and internal movement.

#### Revisions :

Cl. 18.11.01 of MRC – NFCW+HE

#### APPROVED :

INTERPLANT MATERIAL RATIONALIZATION  
COMMITTEE-MRC (NFCW+HE)

Rev. No. 02

Amd.No.

Reaffirmed

Prepared

Issued

Dt. of 1st Issue

Dt: 15.02.2004

Dt :

Year :

HYDERABAD

Corp. R&D

DECEMBER, 1986



**3.4** The U-bent tubes of different radii shall be inserted into the slots of the wooden supports which are firmly fixed in the box as shown in Fig.1

**3.5** The recommended packing case design and the method of packing is illustrated in fig 1. Any alternate method of packing shall be submitted to BHEL with full particulars and drawings along with the offer for approval.

#### **4.0 MARKING:**

**4.1** Each tube shall be stenciled with the following information:

- a) BHEL order number:
- b) BHEL Specification No.
- c) Melt/Heat No:
- d) Size of tube:
- e) Supplier 's mark

**4.2** A metal label shall be securely attached to each packing case, punched with the following details :

- a) BHEL order number:
- b) BHEL Specification No.
- c) Consignment or Identification No.
- d) Size of the tubes & Total weight
- e) Supplier's Name

**4.3** The packing case shall be marked with the following symbols in order to avoid damage during transit:

- a) A mark indicating UP-DOWN position of the case.
- b) A mark indicating that the case shall not be given any impact.
- c) A mark indicating that the case shall be kept free from contact with moisture.
- d) A mark showing the slinging position.

#### **5.0 HANDLING AT PORT, SITE, SHOP, ETC., 9INCLUDING TRANSPORTATION):**

##### **5.1 Procedure:**

If the tube length is more than 7000 mm invariably beams are ordered by BHEL, two in numbers which are supplied with first consignment by the vendor.

On receipt of consignment at port, boxes and lifting beams shall be inspected. If boxes are found broken, inspection of tubes shall be carried out. Broken box shall be suitably repaired before sending to site. Boxes shall be inspected before loading on the truck/trailer at supplier's works. Repair shall be carried out if required.

Invariably lifting beam shall be used for handling of boxes.

Boxes shall be placed on the floor on supports ( at least 300 mm above the floor). Distance between supports shall not be more than 500 mm. While handling /stacking, vertical direction as marked on the box shall be followed.

Boxes shall be stacked on each other in such a way that are upright, straight and not projecting outside the lower box. Normally not more than 3 boxes shall be kept on each other.



## CORPORATE STANDARD

AA 049 00 03

Rev. No. 02

PAGE 3 OF 4

### 5.2 Loading of boxes on trailers/trucks:

Preferably trailer shall be of flat floor and its length shall not less than the box. However, in case it is not feasible, following is recommended:

<u>Box length max. in metres</u>	<u>Floor length not less than in metres</u>
20	18.5
15	14
10	9.5
8	7.6

In case, the floor of trailer/truck is not flat, following procedure shall be adopted:

- Packers of suitable strength shall be placed on the floor such that when boxes are placed, the packer's bottom of the boxes is horizontal.
- Packers shall be placed such that at the driver end, the box projects maximum 300 mm from the support and on the opposite end, it is 300 mm less than end of the floor such that total projection from last support shall not be more than as specified above.
- Boxes shall be placed on each other as specified in clause 5.1. The each vertical row shall be secured tight using ropes /wires and tightened with each other and secured with the trailer floor suitably. The gap between the tightening rope/wire shall not be more than 2 metres.
- Out of two lifting beams, one number shall be sent with first consignment and the second lifting beam with the last consignment.
- Boxes shall be covered with tarpaulin and tightened suitably so as to prevent seepage of water.

### 5.3 Receipt at site:

The boxes shall be again inspected at the site for any breakage, if found shall be reported back to concerned unit.

The boxes from trailer/truck shall be lifted using lifting beam only supplied with the first and last consignment and stacked in the store in line with clause 5.1.

The boxes shall be covered with tarpaulin to prevent water seeping in the boxes.

### 6.0 REFERRED STANDARDS (LATEST PUBLICATIONS INCLUDING AMENDMENTS):

NIL

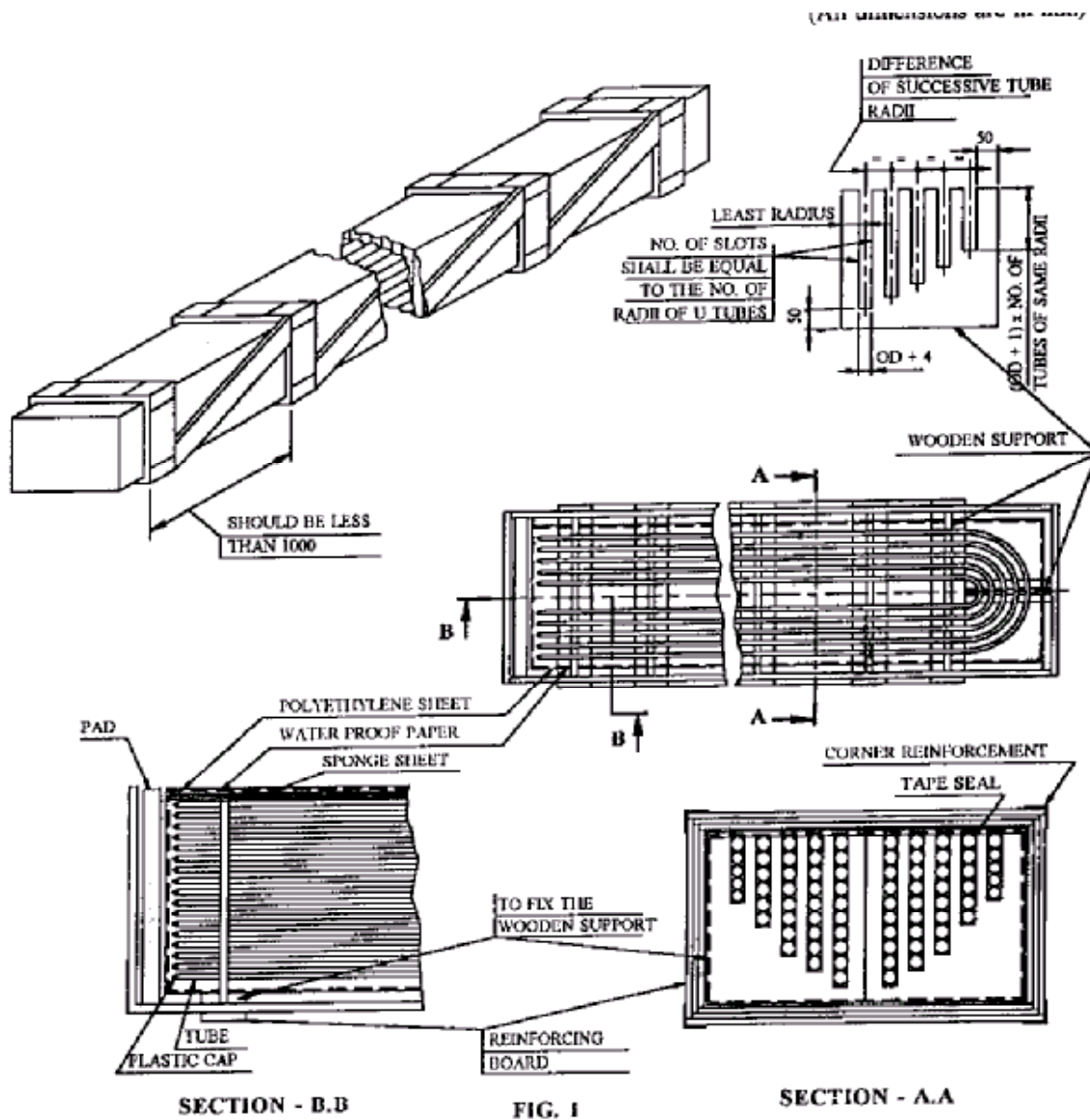

SECTION - B.B

FIG. 1

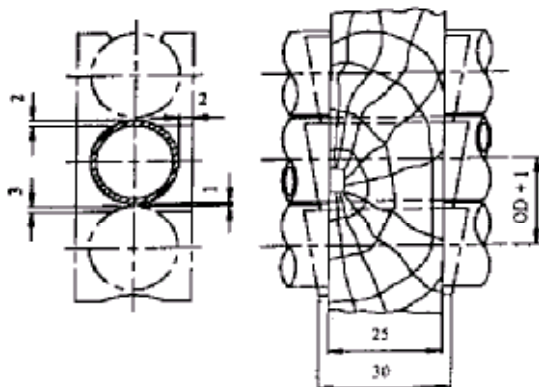

SECTION - A.A

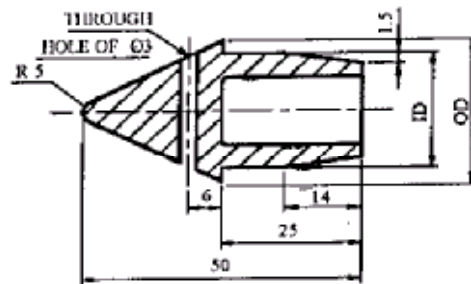

SUPPORT GUIDE DETAIL  
FIG. 2



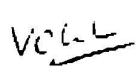

CAP FOR TUBE END  
FIG. 3

TD-106-2 Rev-5	Form No.		<b>PRODUCT STANDARD</b> <b>HEAT EXCHANGERS</b> <b>HYDERABAD</b>		No: <b>HE 5 1173</b>
					REV. NO. <b>10</b>
					Page 1 of 4
<p><b><u>SPECIFICATION FOR SEAMLESS TUBES FOR H.P. HEATERS L.P. HEATERS &amp; DRAIN COOLERS (STAINLESS STEEL TUBES)</u></b></p> <p>1. Bend/straight tubes shall conform to SA 213 TP 304 / TP 304L/ TP 304N/ TP 316 as per drawing/enquiry/P.O with Carbon limited to 0.05 % max. in case of TP 304/ TP 304N/TP 316 and 0.035% in case of TP 304L. Carbon content Specified in the drawing/P.O shall be governing. Tubes shall be seamless cold drawn.</p> <p>2.1 Straight tubes or tubes ready for 'U' bending shall be furnished in the bright annealed condition (both inside and outside surfaces) with a minimum temperature of 1040°C followed by rapid cooling to below 370°C. The cooling rate shall be sufficiently rapid to prevent harmful carbide precipitation.</p> <p>2.2 After U bending U bent portion plus not less than 150 mm (6") of each straight leg of the tube beyond the tangent point of U bend shall be solution annealed to a minimum temp of 1040 °C followed by rapid cooling to below 370°C. U-bent tubes inside shall be purged with inert gas during heat treatment of U-bent portion.</p> <p>2.3 If the heat treatment of the U-bends as specified above is done by resistance heating methods, wherein electrodes are clamped to the tubes, the clamped areas shall be visually examined for arc burns. Burn indications shall be cause for rejection unless they can be removed by local polishing without encroaching upon, minimum wall thickness.</p> <p>Temperature control shall be accomplished through the use of optical or omission pyrometers or both. No temperature indicating crayons, Lacquers or pellets shall be used.</p> <p>3. For tubes supplied in bend condition, tube thinning shall be governed by the following formula.</p> $t = t_o \times (1 + d/4R) \quad \text{where}$ <p>t = Specified minimum wall tube thickness.</p> <p>t<sub>o</sub> = Thickness after bending.</p> <p>D = Outside diameter of tube.</p> <p>R = Center line bend radius.</p> <p>4. Minimum thickness, ovality etc., achieved for minimum bend radius tube for each thickness shall be proved.</p> <p>5. Hot bending to form U tubes shall not be acceptable.</p> <p>6. The tubes shall be tested for corrosion resisting properties as follows :</p> <p>a) One full section sample 1 inch (25.4mm) long from the center of a sample tube of the smallest radius bend which is heat treated shall be tested in the heat treated condition in accordance with practices A262, practice-E.</p>					
Ref.Doc	Revisions:  Refer to record of revisions	Prepared: 	Approved 	Date: 06.05.2004	

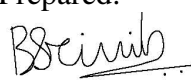
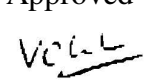
COPYRIGHT AND CONFIDENTIAL  
The information on this document is the property of BHARAT HEAVY ELECTRICALS LIMITED.  
It must not be used directly or indirectly in any way detrimental to the interest of the company

TD-106-2 Rev-5	Form No.		<b>PRODUCT STANDARD</b> <b>HEAT EXCHANGERS</b> <b>HYDERABAD</b>		No: <b>HE 5 1173</b>	
<p style="text-align: center;">COPYRIGHT AND CONFIDENTIAL</p> <p style="text-align: center;">The information on this document is the property of BHARAT HEAVY ELECTRICALS LIMITED. It must not be used directly or indirectly in any way detrimental to the interest of the company</p>					REV. NO. <b>10</b>	
			<p>b) One full section sample 1 inch (25.4mm) long from each lot (“lot” refers to all tubes prior to cutting to length, of the same Nominal dia, and wall thickness, produced from the same heat of steel and annealed in a continuous furnace at the same temperature, time at heat , and furnace speed) of straight tubes shall be tested in the finished condition in accordance with practices A262, practice-E.</p> <p>c) The appearance of any fissures or cracks in the test specimen when evaluated in accordance with practices A262, practice-E. indicating the presence of inter granular attack, shall be cause for rejection of that lot.</p> <p>7. Eddy current test shall be carried out as per E426. Eddy Current testing to be carried out 100% online OR 100% Offline which shall be witnessed by BHEL/BHEL nominated inspection agency (BHEL TPIA) with quantum of inspection 100%. (The The type of notch and acceptance norm shall be Transverse tangential notch as per SA1016.)</p> <p>7a. Flaring test on each lot, atleast two tests from each lot are to be conducted as per SA1016.</p> <p>8. Permissible variation from the specified outside diameter shall not exceed <math>\pm 0.1</math> mm for stainless steel tubes (seamless). This includes ovality also.</p> <p>9. Permissible variations from the specified wall thickness.</p> <p>a) Permissible variations from the specified minimum wall thickness shall not exceed +20% - 0.</p> <p>b) Permissible variation from the specified average wall thickness are <math>\pm 10\%</math> of the nominal wall thickness.</p> <p>10. At the bend portion of the U-tube for <math>R=1.5x d</math> or greater neither the major nor minor diameter of tube shall deviate from nominal prior to bending by more than 10%.</p> <p>11. Leg spacing measuring between the points of tangency of the bend to the legs shall not vary from the value (2R- specified tube O.D) by more than 1.5 mm. Where ‘R’ is the center line bend radius.</p> <p>12. The bend portion of the U-tube shall be substantially uniform in curvature and not exceed the normal center line radius by <math>\pm 1.5</math> mm.</p> <p>13. Permissible deviation from the plane of bend shall not exceed 1.5 mm as measured from point of tangency.</p> <p>14. Each tube shall be subjected to the hydrostatic test by DM water with a chloride content not exceeding 10 PPM, to the pressure indicated in the drawing / enquiry / P.O.</p> <p>15. Manufacturing, inspection, testing, certification &amp; marking shall fully confirm to SA 213 TP 304 / TP 304L/ TP 304N/ TP 316 (as per drawing /enquiry / P.O) of ASME SEC II PART A, year of edition and addenda as indicated in drawing / enquiry / P.O and as per this standard.</p> <p>16. Packing shall be seaworthy and capable of withstanding mechanical damage. Tube ends shall be capped or plugged for protection against ingress of moisture / water during transit &amp; storage. Supplier shall submit packing procedure with sketch of packing box along with the offer for BHEL’s approval.</p>		Page 2 of 4	
			Ref.Doc	Revisions:  Refer to record of revisions	Prepared: 	Approved 

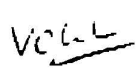
TD-106-2 Rev-5	Form No.		<b>PRODUCT STANDARD</b> <b>HEAT EXCHANGERS</b> <b>HYDERABAD</b>		No: <b>HE 5 1173</b>
					REV. NO. <b>10</b>
					Page 3 of 4
<p style="writing-mode: vertical-rl; transform: rotate(180deg);">           COPYRIGHT AND CONFIDENTIAL            The information on this document is the property of BHARAT HEAVY ELECTRICALS LIMITED.            It must not be used directly or indirectly in any way detrimental to the interest of the company         </p> <p>17. Supplier shall furnish test certificates in 6 copies. Test certificates shall contain the following information duly attested by BHEL Approved Third Party Inspection Agency, Additionally by Director Of Boilers for H.P. Heaters in case of indigenous supplies.</p> <ul style="list-style-type: none"> <li>a) Purchase order No and Grade</li> <li>b) Specification No and Grade</li> <li>c) Heat No and Heat analysis</li> <li>d) Product analysis</li> <li>e) Size, thickness and quantity of tubes</li> <li>f) Results of all test as per specification &amp; as per this standard carried out with BHEL Approved Third Party Inspection Agency.</li> </ul> <p>18. Tubes inside &amp; Outside surfaces shall be tested for residual chloride salt contamination to limits as per SA 688. The same shall be reported in Test Certificates. Procedure of measuring residual chloride contamination shall be furnished.</p> <p>19. Cleanliness of inside surface of all U tube shall be confirmed by blowing close fitting acetone soaked felt plugs. Inert gas or N2 shall be used for blowing.</p> <p>20. In the event of an order supplier shall furnish annealing procedure in advance for approval and also furnish co-related TC with all relevant details of heat treatment in accordance with approved procedure.</p> <p>21. ----</p> <p>22. ----</p> <p>23. Packing &amp; Marking for U tubes – AA 049003.</p> <p>24. Packing &amp; Marking for Straight Tubes – AA049002.</p> <p>25. Inspection and certification :</p> <ul style="list-style-type: none"> <li>i) H.P.HEATERS:             <ul style="list-style-type: none"> <li>a) where the material is sourced from suppliers other than India ,the certification shall be in IBR form III B duly signed by BHEL Approved Third Party Inspection Agency(BHEL TPIA).BHEL TPIA shall be authorised by Central Boiler Board for that country.</li> <li>b) Where the material is sourced from Indigenous Suppliers, the certification shall be by Director of Boilers in form III B and also by BHEL Approved Third Party Inspection Agency(BHEL TPIA) as per ASME SEC.II Part A.Edition &amp; Addenda as indicated in the drawing/P.O &amp; enclosed quality plan.</li> </ul> </li> <li>ii) L.P.HEATERS &amp; DRAIN COOLER:             <ul style="list-style-type: none"> <li>a) Inspection &amp; Certification shall be by BHEL Approved Third party Inspection Agency(BHEL TPIA) as per ASME SEC.II Part A. Edition &amp; Addenda as indicated in the drawing/P.O &amp; enclosed quality plan.</li> </ul> </li> </ul>					
Ref.Doc	Revisions:  Refer to record of revisions	Prepared: 	Approved 	Date: 06.05.2004	



TD-106-3

Rev-5

Form No.



**PRODUCT STANDARD**  
**HEAT EXCHANGERS**  
**HYDERABAD**

No: **HE 5 1173**

REV. NO. 10

Page 4 of 4

**RECORD OF REVISIONS**

Rev. No.	Date	Revision Details	Revised	Approved
04	18-09-93	STD. REWRITTEN AS PER NEW FORMAT	B.U.G	D.S
05	31-12-94	CL. Nos. 1, 14, 15 REVISED	B.U.G	D.S
06	10-06-96	CL. No. 17 REVISED	M.R.RAO	V.C.K
07	24-05-97	CL. 21 & CL. 22 - ADDED	M.R.RAO	V.C.K
08	10-03-03	Revised in line with SQP and PRQC meeting dated: 28.12.02	B.S	V.S
09	06-05-04	Revised inline with MOM dated:30-03-04	BScinib	V.C.K
10	27-11-13	Revised inline with MOM dated:26-10-13	Rivan	BScinib

COPYRIGHT AND CONFIDENTIAL

The information on this document is the property of BHARAT HEAVY ELECTRICALS LIMITED. It must not be used directly or indirectly in any way detrimental to the interest of the company



BHARAT HEAVY ELECTRICALS  
LIMITED  
R.C.PURAM, HYDERABAD

STANDARD QUALITY PLAN FOR VENDOR ITEMS

ITEM: SEAMLESS SS 'U' TUBES FOR HP HEATERS & LP HEATERS

BHEL SPEC: HE 51173 Rev. 10

PROJECT : 2X660 MW MAITREE SUPERCRITICAL TPP, BANGLADESH

QP. NO: HY/HE/010/U-TUBE

REV. NO. : 04

DATE: 23.05.2017

VALID UPTO: 22.05.2019

PAGE 1 OF 6

SL NO	COMPONENT & OPERATIONS	CHARACTERISTICS	CLASS	TYPE OF CHECK	QUANTUM OF CHECK	REF DOCUMENT	ACCEPTANCE NORMS	FORMAT OF RECORD	* D	AGENCY			REMARKS
										P	W	V	
<b>1.0 RAW MATERIAL INSPECTION</b>													
1.1	MOTHER TUBES	A) IDENTIFICATION OF MOTHER TUBES MARKINGS W.R.TO TC	MAJOR	VISUAL	100%	TEST CERTIFICATE	BHEL SPECIFICATION	TC & INSPN. RECORD		2	1*		* VERIFY & RANDOM WITNESS NOTE-13
		B) VISUAL & DIMN. EXAM	MAJOR	VISUAL & MEASRT	100%	TEST CERTIFICATE	BHEL SPECIFICATION	TC & INSPN. RECORD		2		1	
1.2	VERIFICATION OF MOTHER TUBES TEST CERTIFICATE	A) CHEMICAL COMP.	MAJOR	CHEM.	100%	TEST CERTIFICATE	BHEL SPECIFICATION	TC & INSPN. RECORD	✓	2		1	CARBON CONTENT LIMIT SHALL BE AS PER BHEL SPECIFICATION
		B) MECH. PROPERTIES	MAJOR	MECH.	100%	TEST CERTIFICATE	BHEL SPECIFICATION	TC & INSPN. RECORD	✓	2		1	
		C) UT	MAJOR	NDE/INTERNAL FLAW	100%	TEST CERTIFICATE	BHEL SPECIFICATION	TC & INSPN. RECORD	✓			1	NOTE-13
<b>2.0 IN PROCESS INSPECTION</b>													
2.1	PILGERING / INTERMEDIATE DRAWING	COLD PILGERING / COLD DRAWING	MAJOR	OD, THK, SURFACE	100%	MFR STD	BHEL SPECIFICATION	-DO-	✓	2		1	
2.2	TUBE WASHING	SURFACE CONDITION	MAJOR	VISUAL	100%	MFR STD	BHEL SPECIFICATION	-DO-	✓	2		1	
2.3	INTERMEDIATE HEAT TREATMENT	SOLUTION ANNEALING	MAJOR	TEMP, SOAKING TIME, SPEED	100%	BHEL SPECIFICATION	BHEL SPECIFICATION	-DO-	✓	2		1	
2.4	FINAL DRAWING & SIZING	COLD DRAWN	MAJOR	OD, WALL THK & SURFACE	100%	MFR STD	BHEL SPECIFICATION	-DO-		2	1*		* VERIFY & RANDOM WITNESS

LEGEND:  
P: - PERFORM, W: - WITNESS, V: - VERIFICATION,  
INDICATING 1: - BHEL / BHEL NOMMNATED INSPECTION AGENCY, 2: - VENDOR / SUB VENDOR  
3: CUSTOMER / CUSTOMER TPIA AS APPROPRIATE AGAINST EACH COMPONENT / CHARACTERISTICS UNDER THE COLUMNS P, W & V.  
\* D: RECORDS IDENTIFIED WITH TICK (✓) SHALL BE ESSENTIALLY INCLUDED IN QA DOCUMENTATION.

PREPARED BY:

*Alok Behera*

**ALOK BEHERA**  
SR.ENGR/ QA

REVIEWED BY:

*D S Satpute*

**D S SATPUTE**  
AGM /QA

APPROVED BY:

*D S Satpute*

**D S SATPUTE**  
AGM /QA



BHARAT HEAVY ELECTRICALS  
LIMITED  
R.C.PURAM, HYDERABAD

STANDARD QUALITY PLAN FOR VENDOR ITEMS  
ITEM: SEAMLESS SS 'U' TUBES FOR HP HEATERS & LP HEATERS  
BHEL SPEC: HE 51173 Rev. 10  
PROJECT : 2X660 MW MAITREE SUPERCRITICAL TPP, BANGLADESH

QP. NO: HY/HE/010/U-TUBE  
REV. NO. : 04  
DATE: 23.05.2017  
VALID UPTO: 22.05.2019  
PAGE 2 OF 6

SL NO	COMPONENT & OPERATIONS	CHARACTERISTICS	CLASS	TYPE OF CHECK	QUANTUM OF CHECK	REF DOCUMENT	ACCEPTANCE NORMS	FORMAT OF RECORD	* D	AGENCY			REMARKS
										P	W	V	
2.5	FINAL HEAT TREATMENT	BRIGHT ANNEALING IN INERT ATMOSPHERE	MAJOR	TEMP, HOLDING TIME, RATE OF COOLING	100%	BHEL SPECIFICATION	BHEL SPECIFICATION	H T CHART	✓	2		1	NOTE 3
2.6	STRAIGHTENING	STRAIGHTNESS	MAJOR	OD, SURFACE	100%	BHEL SPECIFICATION	BHEL SPECIFICATION	INSPN. RECORD		2			
2.7	CUT TO LENGTH WITH ALLOWANCE	LENGTH	MAJOR	MEASRT	100%	BHEL SPECIFICATION & PO	BHEL SPECIFICATION & PO	INSPN. RECORD		2			
2.8	SAMPLING FOR TESTING		MAJOR	MEASRT	100%	BHEL SPECIFICATION & PO	BHEL SPECIFICATION & PO	INSPN. RECORD		2	1		
2.9	TEST ON TUBES	a) PRODUCT ANALYSIS	MAJOR	CHEMICAL	AS PER SPEC.	SA213, SA1016 & PO	SA213, SA1016 & PO	SUPPLIERS TC	✓	2		1	CARBON CONTENT LIMIT SHALL BE AS PER BHEL SPECIFICATION
		b) TENSILE TESTING	MAJOR	MECH.	AS PER SPEC.	SA213, SA1016 , BHEL SPECIFICATION & PO	SA213, SA1016 , BHEL SPECIFICATION & PO	TC & INSPN. RECORD	✓	2	1		
		c) HARDNESS TESTING	MAJOR	MECH.	AS PER SPEC.			TC & INSPN. RECORD	✓	2	1		
		d) FLATTENING TEST	MAJOR	MECH.	AS PER SPEC.			TC & INSPN. RECORD	✓	2	1		
		e) FLARING TEST	MAJOR	MECH.	AS PER SPEC.			TC & INSPN. RECORD	✓	2	1		
		f) INTER GRANULAR CORROSION TESTING	MAJOR	CORROSION RESISTANCE	AS PER SPEC.			TC & INSPN. RECORD	✓	2		1	
		g) RESIDUAL CHLORIDE	MAJOR	CHEM.	AS PER SPEC.			TC & INSPN. RECORD	✓	2		1	
		h) MICROSTRUCTURE, GRAIN PROPERTIES	MAJOR	METALLOGRAPHY	ONE PER HEAT	BHEL SPEC.	BHEL SPEC. & P.O	TC	✓	2		1	

LEGEND:  
P: - PERFORM, W: - WITNESS, V: - VERIFICATION,  
INDICATING 1: - BHEL / BHEL NOMMINATED INSPECTION AGENCY, 2: - VENDOR / SUB VENDOR  
3: CUSTOMER / CUSTOMER TPIA AS APPROPRIATE AGAINST EACH COMPONENT / CHARACTERISTICS UNDER THE COLUMNS P, W & V.  
\* D: RECORDS IDENTIFIED WITH TICK (✓) SHALL BE ESSENTIALLY INCLUDED IN QA DOCUMENTATION.

PREPARED BY:

*Alok Behera*

**ALOK BEHERA  
SR.ENGR/ QA**

REVIEWED BY:

*D S Satpute*

**D S SATPUTE  
AGM /QA**

APPROVED BY:

*D S Satpute*

**D S SATPUTE  
AGM /QA**



BHARAT HEAVY ELECTRICALS  
LIMITED  
R.C.PURAM, HYDERABAD

STANDARD QUALITY PLAN FOR VENDOR ITEMS

ITEM: SEAMLESS SS 'U' TUBES FOR HP HEATERS & LP HEATERS

BHEL SPEC: HE 51173 Rev. 10

PROJECT : 2X660 MW MAITREE SUPERCRITICAL TPP, BANGLADESH

QP. NO: HY/HE/010/U-TUBE

REV. NO. : 04

DATE: 23.05.2017

VALID UPTO: 22.05.2019

PAGE 3 OF 6

SL NO	COMPONENT & OPERATIONS	CHARACTERISTICS	CLASS	TYPE OF CHECK	QUANTUM OF CHECK	REF DOCUMENT	ACCEPTANCE NORMS	FORMAT OF RECORD	* D	AGENCY			REMARKS
										P	W	V	
2.10	EDDY CURRENT TEST	INTERNAL FLAWS	MAJOR	NDE	100% 5 % WITNESS BY CUSTOME R	ASTM E426	ASME SA1016 & NOTE 8	SUPPLIER TC	✓	2	1*	3	*100% ONLINE OR 100% OFFLINE. NOTE 11
2.11	ULTRASONIC TEST	INTERNAL FLAWS	MAJOR	NDE	100 % BY MFR , 10 % BY BHEL	ASTM E213	ASME SA1016	SUPPLIER TC	✓	2	1		
2.12	INSPECTION OF STRAIGHT TUBES	OD, THICKNESS, LENGTH, STRAIGHTNESS, EDGE BURRS, SURFACE CONDITION	MAJOR	VISUAL & MEASRT	100 %	MFR. STD.	MFR. STD., BHEL SPEC	-DO-		2		1	
2.13	U-BENDING OF TUBES	CENTRE LINE BEND RADIUS (CLR)	MAJOR	VISUAL	100%	MFR. STD.	MFR. STD.	INSPN. RECORD		2		1	NOTE 4
		WALL THINNING	MAJOR	MEASRT	1 SAMPLE OF MIN BEND RADIUS FOR EACH THK	BHEL SPECIFICATION & DRG.	BHEL SPECIFICATION & DRG.	INSPN. RECORD		2		1	
2.14	STRESS RELIEVING OF U- BEND PORTION	SOLUTION ANNEALING	MAJOR	TEMP, SOAKING TIME	100%	BHEL SPECIFICATION & DRG.	BHEL SPECIFICATION & DRG.	INSPN. RECORD	✓	2		1	NOTE 5

LEGEND:  
P: - PERFORM, W: - WITNESS, V: - VERIFICATION,  
INDICATING 1: - BHEL / BHEL NOMNATED INSPECTION AGENCY, 2: - VENDOR / SUB VENDOR  
3 : CUSTOMER / CUSTOMER TPIA AS APPROPRIATE AGAINST EACH COMPONENT / CHARACTERISTICS UNDER THE COLUMNS P, W & V.  
\* D: RECORDS IDENTIFIED WITH TICK (✓) SHALL BE ESSENTIALLY INCLUDED IN QA DOCUMENTATION.

PREPARED BY:

**ALOK BEHERA**  
SR.ENGR/ QA

REVIEWED BY:

**D S SATPUTE**  
AGM /QA

APPROVED BY:

**D S SATPUTE**  
AGM /QA



BHARAT HEAVY ELECTRICALS  
LIMITED  
R.C.PURAM, HYDERABAD

STANDARD QUALITY PLAN FOR VENDOR ITEMS

ITEM: SEAMLESS SS 'U' TUBES FOR HP HEATERS & LP HEATERS

BHEL SPEC: HE 51173 Rev. 10

PROJECT : 2X660 MW MAITREE SUPERCRITICAL TPP, BANGLADESH

QP. NO: HY/HE/010/U-TUBE

REV. NO. : 04

DATE: 23.05.2017

VALID UPTO: 22.05.2019

PAGE 4 OF 6

SL NO	COMPONENT & OPERATIONS	CHARACTERISTICS	CLASS	TYPE OF CHECK	QUANTUM OF CHECK	REF DOCUMENT	ACCEPTANCE NORMS	FORMAT OF RECORD	* D	AGENCY			REMARKS
										P	W	V	
2.1.5	STRESS RELIEVING	RESIDUAL CIRCUMFERENTIAL STRESS	MAJOR	MEASRT	ONE SPECIMEN PER LOT	PO & DRG.	PO & DRG.	INSPN. RECORD	✓	2	1		PROCEDURE FOR RESIDUAL STRESS MEASUREMENT AS APPROVED BY BHEL TO BE FOLLOWED
<b>3.0</b>	<b>FINAL INSPECTION</b>												
3.1	HYDROSTATIC TESTING	PRESSURE, TIME, LEAKAGE	CRITICAL	HYDRO	100% (5% WITNESS BY CUSTOMER)	ASTM A1016	ASTM A1016	HYDRO TEST REPORT	✓	2	1, 3		CHP, NOTE 6 NOTE 12
3.2	CUT TO LENGTH & DEBURR	LENGTH, EDGE CONDITION	MAJOR	MEASRT	100%	BHEL SPECIFICATION & PO	BHEL SPECIFICATION & PO	INSPN. RECORD		2		1	
3.3	DIMN. CONFORMITY & VISUAL EXAM.	OD, CLR, THICKNESS, LENGTH, OVALITY, LEG SPACING, PLANE OF BEND, CURVATURE, EDGE BURRS.	MAJOR	MEASRT	100%	DRG. / PO & SPEC	DRG. / PO & SPEC	INSPN. RECORD	✓	2	1*		* VERIFY & RANDOM WITNESS
3.4	CLEANLINESS OF INSIDE SURFACE OF TUBES	NITROGEN PURGING	MAJOR	MEASRT	100%	DRG. / PO & SPEC	DRG. / PO & SPEC	INSPN. RECORD	✓		1*		* VERIFY & RANDOM WITNESS
<b>4.0</b>	<b>PRESERVATION AND DESPATCH</b>												
<b>4.1</b>	<b>PACKING &amp; DESPATCH</b>	VERIFICATION OF ALL TCS FOR COMPLETION.	MAJOR	VISUAL	100%	PO, SPEC., DRG. & QP	DRG. / PO & SPEC	INSPN. RECORD	✓	2		1	

LEGEND:  
P: - PERFORM, W: - WITNESS, V: - VERIFICATION,  
INDICATING 1: - BHEL / BHEL NOMINATED INSPECTION AGENCY, 2: - VENDOR / SUB VENDOR  
3: CUSTOMER / CUSTOMER TPIA AS APPROPRIATE AGAINST EACH COMPONENT / CHARACTERISTICS UNDER THE COLUMNS P, W & V.  
\* D: RECORDS IDENTIFIED WITH TICK (✓) SHALL BE ESSENTIALLY INCLUDED IN QA DOCUMENTATION.

PREPARED BY:

**ALOK BEHERA**  
SR.ENGR/ QA

REVIEWED BY:

**D S SATPUTE**  
AGM /QA



APPROVED BY:

**D S SATPUTE**  
AGM /QA

		<b>BHARAT HEAVY ELECTRICALS LIMITED</b> R.C.PURAM, HYDERABAD		<b>STANDARD QUALITY PLAN FOR VENDOR ITEMS</b>				<b>QP. NO: HY/HE/010/U-TUBE</b> <b>REV. NO. : 04</b> <b>DATE: 23.05.2017</b> <b>VALID UPTO: 22.05.2019</b>					
				<b>ITEM: SEAMLESS SS 'U' TUBES FOR HP HEATERS &amp; LP HEATERS</b> <b>BHEL SPEC: HE 51173 Rev. 10</b> <b>PROJECT : 2X660 MW MAITREE SUPERCRITICAL TPP, BANGLADESH</b>				<b>PAGE 5 OF 6</b>					
SL NO	COMPONENT & OPERATIONS	CHARACTERISTICS	CLASS	TYPE OF CHECK	QUANTUM OF CHECK	REF DOCUMENT	ACCEPTANCE NORMS	FORMAT OF RECORD	* D	AGENCY			REMARKS
										P	W	V	
		PMI	MAJOR	NDE	10 % BY MFR	BHEL SPECIFICATION & PO.	BHEL SPECIFICATION & PO.	INSPN. RECORD	✓	2	1		RANDOM WITNESS BY BHEL TPIA
		REVIEW OF REJECTION REPORT	MAJOR	VISUAL	100 %	PO, SPEC., DRG. & QP	DRG. / PO & SPEC	INSPN. RECORD	✓	2		1	*CHP NOTE 12
		PACKING & DISPATCH	MAJOR	VISUAL	100 %	PO, SPEC., DRG. & QP	DRG. / PO & SPEC	INSPN. RECORD	✓	2	1*		* VERIFY & RANDOM WITNESS

**NOTES:**

- LUBRICANTS USED IN TUBE DRAWING OPERATION SHALL BE NON-CHLORINATED (50 PPM CHLORIDES OR LESS). ALL CLEANING COMPOUNDS SHALL BE CHLORIDE AND CAUSTIC FREE. EACH CLEANING OPERATION SHALL BE FOLLOWED BY A RINSE OR RINSES WITH WATER, THE FINAL RINSE SHALL BE WITH DEMINERALISED WATER CONTAINING NOT MORE THAN 10 PPM CHLORIDES.
- INTERMEDIATE SOLUTION ANNEALING SHALL ALSO BE DONE IN BRIGHT ANNEALING FURNACE ONLY.
- STRAIGHT TUBES SHALL BE CLEANED AND BRIGHT ANNEALED AT A TEMPERATURE OF 1040°C MIN. FOLLOWED BY QUENCHING TO BELOW 370° C. BHEL TPIA SHALL CHECK PARAMETER SETTINGS AND SAME SHALL BE MENTIONED IN REPORT.
- HOT BENDING TO FORM 'U' TUBES SHALL NOT BE PERMITTED.
- U BEND AREA PLUS APPROXIMATELY 150MM OF EACH LEG BEYOND TANGENT POINT OF THE U BEND SHALL BE HEAT TREATED.
- HYDROSTATIC TESTING OF TUBES SHALL BE CARRIED OUT WITH DEMINERALISED WATER. CHLORIDE CONTENT OF D.M. WATER SHALL NOT EXCEED 10 PPM.
- TUBES SHALL BE PACKED IN SEA WORTHY PACKING & SHALL BE CAPABLE OF WITHSTANDING MECHANICAL DAMAGES DURING TRANSIT.
- EDDY CURRENT TEST SHALL BE CARRIED OUT WITH A TRANSVERSE TANGENTIAL NOTCH AS PER SA1016
- PROJECT SPECIFIC REQUIREMENTS, IF ANY, AS PER PO SHALL ALSO BE COMPLIED WITH. VENDOR HOLDS THE RESPONSIBILITY OF SUPPLYING TUBES TO THE SPECIFICATION AND RELEVANT STANDARDS.
- THE REQUIRED CERTIFICATION FOR HP HEATER U-TUBES FROM IBR IN IBR FORM III B FORMAT SHALL BE FURNISHED TO BHEL.
- ALL TUBES PASSED IN EDDY CURRENT TEST SHALL BE MARKED BY ELECTRO-STENCILLING BY BHEL/BHEL TPIA. ALL REJECTED TUBES SHALL BE REMOVED FROM WORK AREA IN PRESENCE OF BHEL/BHEL TPIA
- VENDOR TO PERFORM ROOT CAUSE ANALYSIS AND SUBMIT REPORT TO BHEL, IN CASE OF ANY REJECTION OF TUBES DURING HYDROTEST FAILURE.
- BHEL TPIA SHALL CHECK RANDOM 5 SAMPLES FROM EACH LOT AND VERIFY CO-RELATION WITH TCS DURING RAW MATERIAL INDUCTION & VERIFICATION OF BALANCE TCS. RAW MATERIALS SHALL BE PROCURED FROM BHEL APPROVED SOURCES:
- IN CASE OF NEW VENDOR (EXECUTING BHEL ORDER FOR FIRST TIME), IN ADDITION TO BHEL TPIA, BHEL QC SHALL ALSO INSPECT/WITNESS STAGE/FINAL INSPECTION AT RANDOM AS A SURVEILLANCE CHECK.

<b>LEGEND:</b> P: - PERFORM, W: - WITNESS, V: - VERIFICATION, INDICATING 1:- BHEL / BHEL NOMMINATED INSPECTION AGENCY, 2: - VENDOR / SUB VENDOR 3 : CUSTOMER / CUSTOMER TPIA AS APPROPRIATE AGAINST EACH COMPONENT / CHARACTERISTICS UNDER THE COLUMNS P, W & V. * D: RECORDS IDENTIFIED WITH TICK (✓) SHALL BE ESSENTIALLY INCLUDED IN QA DOCUMENTATION.	<b>PREPARED BY:</b>  <b>ALOK BEHERA</b> <b>SR.ENGR/ QA</b>	<b>REVIEWED BY:</b>  <b>D S SATPUTE</b> <b>AGM /QA</b>	<b>APPROVED BY:</b>  <b>D S SATPUTE</b> <b>AGM /QA</b>
	Format no. : HYQA/QP/VSQP Rev.02		



BHARAT HEAVY ELECTRICALS  
LIMITED  
R.C.PURAM, HYDERABAD

STANDARD QUALITY PLAN FOR VENDOR ITEMS

ITEM: SEAMLESS SS 'U' TUBES FOR HP HEATERS & LP HEATERS

BHEL SPEC: HE 51173 Rev. 10

PROJECT : 2X660 MW MAITREE SUPERCRITICAL TPP, BANGLADESH

QP. NO: HY/HE/010/U-TUBE

REV. NO. : 04

DATE: 23.05.2017

VALID UPTO: 22.05.2019

PAGE 6 OF 6

SL NO	COMPONENT & OPERATIONS	CHARACTERISTICS	CLASS	TYPE OF CHECK	QUANTUM OF CHECK	REF DOCUMENT	ACCEPTANCE NORMS	FORMAT OF RECORD	*	AGENCY			REMARKS
										D	P	W	

MTC – MILL TEST CERTIFICATE

TC – TEST CERTIFICATE

IR – INSPECTION REPORT

COC – CERTIFICATE OF CONFORMITY

TPIA – THIRD PARTY INSPECTION AGENCY APPOINTED BY BHEL.

PO – PURCHASE ORDER NDE - NON-DESTRUCTIVE EXAMINATION

UT – ULTRASONIC TEST MEASRT – MEASUREMENT MFR – MANUFACTURER

STD – STANDARD SPEC - SPECIFICATION

LEGEND:  
P: - PERFORM, W: - WITNESS, V: - VERIFICATION,  
INDICATING 1: - BHEL / BHEL NOMMINATED INSPECTION AGENCY, 2: - VENDOR / SUB VENDOR  
3 : CUSTOMER / CUSTOMER TPIA AS APPROPRIATE AGAINST EACH COMPONENT / CHARACTERISTICS  
UNDER THE COLUMNS P, W & V.  
\* D: RECORDS IDENTIFIED WITH TICK (✓) SHALL BE ESSENTIALLY INCLUDED IN QA DOCUMENTATION.

PREPARED BY:

ALOK BEHERA  
SR.ENGR/ QA

REVIEWED BY:

D S SATPUTE  
AGM /QA

APPROVED BY:

D S SATPUTE  
AGM /QA

**Guidelines for Indian Agents of Foreign Suppliers**

- 1.0 There shall be compulsory registration of agents for all Global (Open) Tender and Limited Tender. An agent who is not registered with BHEL shall apply for registration in the registration form in line with SEARP.
  - 1.1 Registered agents will file an authenticated Photostat copy duly attested by a Notary Public/Original certificate of the Principal confirming the agency agreement and giving the status being enjoyed by the agent and the commission/ remuneration/ salary/ retainership being paid by the principal to the agent before the placement of order by BHEL.
  - 1.2 Wherever the Indian representatives have communicated on behalf of their principals and the foreign parties have stated that they are not paying any commission to the Indian agents, and the Indian representative is working on the basis of salary or as retainer, a written declaration to this effect should be submitted by the party (i.e. Principal) before finalizing the order.
- 2.0 Disclosure of particulars of agents/ representatives in India, if any.**
- 2.1 Tenderers of Foreign nationality shall furnish the following details in their offers:
    - 2.1.1 The Bidder(s)/ Contractor(s) of foreign origin shall disclose the name and address of the agents/ representatives in India if any and the extent of authorization and authority given to commit the Principals. In case the agent/ representative be a foreign Company, it shall be confirmed whether it is existing Company and details of the same shall be furnished.
    - 2.1.2 The amount of commission/ remuneration included in the quoted price(s) for such agents/ representatives in India.
    - 2.1.3 Confirmation of the Tenderer that the commission/ remuneration, if any, payable to his agents/ representatives in India, may be paid by BHEL in Indian Rupees only.
  - 2.2 Tenderers of Indian Nationality shall furnish the following details in their offers:
    - 2.2.1 The Bidder(s)/ Contractor(s) of Indian Nationality shall furnish the name and address of the foreign principals, if any, indicating their nationality as well as their status, i.e. whether manufacturer or agents of manufacturer holding the Letter of Authority of the Principal specifically authorizing the agent to make an offer in India in response to tender either directly or through the agents/ representatives.
    - 2.2.2 The amount of commission/ remuneration included in the price (s) quoted by the Tenderer for himself.
    - 2.2.3 Confirmation of the foreign principals of the Tenderer that the commission/ remuneration, if any, reserved for the Tenderer in the quoted price(s), may be paid by BHEL in India in equivalent Indian Rupees on satisfactory completion of the Project or supplies of Stores and Spares in case of operation items.
  - 2.3 In either case, in the event of contract materializing, the terms of payment will provide for payment of the commission/ remuneration, if any payable to the agents/ representatives in India in Indian Rupees on expiry of 90 days after the discharge of the obligations under the contract.
  - 2.4 Failure to furnish correct and detailed information as called for in paragraph 2.0 above will render the concerned tender liable to rejection or in the event of a contract materializing, the same liable to termination by BHEL. Besides this there would be a penalty of banning business dealings with BHEL or damage or payment of a named sum.



**Annexure-B**

This format is applicable only to Indian Suppliers/ Agents supplying indigenous portion of Foreign Purchases.

\* In all other cases, extant guidelines of SEARP, 2010 are to be followed.

<b>SEARP (SRF) Clause No</b>	<b>Detail</b>
	<b>Name &amp; address of the firm</b>
<b>1.0</b>	<b>Products/ Systems / Services being considered for</b>
<b>2.0</b>	<b>General Information</b>
2.2	Name of Chief Executive
2.3	Details of authorized signatory
<b>3.0</b>	<b>Ownership Information</b>
3.1	Type of firm
3.2	Nature of Business <ul style="list-style-type: none"> <li>• <i>Attach <b>authorization letter</b> and <b>agency agreement</b> from Principal ( from whom capital equipment is procured)</i></li> <li>• <i>Attach copy of declaration from Foreign Principal for <b>total guarantee/ warranty of indigenous supplies</b></i></li> </ul>
3.3	Year of establishment
3.4	Year of commencement of business
<b>4.0</b>	<b>Registration particulars</b>
4.1	Permanent Account No.
4.2 / 4.3	Sales Tax / TIN no
4.6	Service tax no. (in case of E&C)
<b>5.0</b>	<b>Organisational strength</b>
<b>6.0</b>	<b>Other particulars</b>
6.1	If the company is already registered with other units
6.2	Directors/ Partners, if related to any BHEL Employee
6.9	If any Ex BHEL Personnel employed by the Company
6.12	Details of pending legal issues with BHEL
6.13	Bank Account information
<b>9.0</b>	<b>Financial information</b>
9.6	Sales/ Turnover details of last 3 years (or from the date of incorporation whichever is less )

**Annexure-I****Major Activity timelines shall be considered for indigenous purchases**

<b>S.No.</b>	<b>Actiivity</b>	<b>Agency</b>	<b>Timeline</b>
1	Raising of Inspection Call	Vendor	3 working days prior to proposed inspection date
2	Attending Inspection Call	BHEL / Third Party Inspection Agency	3 working days from inspection call date
3	Despatch Clearance / Road Permit	BHEL	3 working days from date of receipt of inspection report

## ***Annexure -II Non-Disclosure Agreement***

### **Confidentiality Agreement**

This **CONFIDENTIALITY AGREEMENT** (“**Agreement**”, which expression shall unless it be repugnant to the subject or context thereof, include all schedules and amendments thereof made from time to time) is made on the date set out in Schedule ) hereof (the “**Effective Date**”) between the person (s) named in Schedule hereof (the “**Receiving Party**”) of the One Part.

**And**

**BHEL LIMITED**, a company incorporated under the companies Act, 1956 and a banking company within the meaning of the banking Regulation Act. 1949 and having its registered office at / its corporate office at BHEL Towers, ----- and the Zonal branch/branch office at \_\_\_\_\_ (“**BHEL**”, which expression shall, unless it be repugnant to the subject or context thereof, include its successors and assigns) of the Other Parts.

The Receiving Party and BHEL are hereinafter collectively referred to as “Parties and individually as a “Party”,

#### **PREAMBLE:**

- (i) BHEL is considering a project involving ----- (Insert Company Name & brief description of Project), the Receiving Party (“ the Project” ), as more particularly specified in detail in Schedule 2 of this agreement for which BHEL will divulge certain information to the Receiving Party which at present is confidential and not in the public domain.
- (ii) BHEL intends that the aforesaid information be kept confidential as between the Receiving Party and BHEL and the Receiving Party undertakes and declares that it shall not divulge, publish or reproduce the same before and person except in accordance with the terms of this Agreement.

THEREFORE, IN COSIDERATION OF BHEL making available such confidential information as aforesaid to the Receiving Party, the Parties agree as follow

(1) For the purpose of this Agreement, “AFFILIATE” of BHEL shall mean and include:

- (a) Any company which is holding company or subsidiary of BHEL, or
- (b) A person under the control of or under common control with BHEL, or
- (c) Any person, in more than 26% of the voting securities of which BHEL has a direct or beneficial interest.

For the purpose of this Affiliate and Agreement, “control” together with grammatical variations when used with respect to any Person, means the power to direct the management and policies of such Person, directly or indirectly, Whether through the owner ship of the vote carrying Securities, by contract or

otherwise however; and "Person" means the company, corporation, a partnership, trust or any other entity or organization or other body whatsoever.

- (2) The Receiving Party hereby agrees that all the confidential, proprietary or trade secret information relating to BHEL including without limitation, information regarding the business operations, financial information, customer information and marketing strategies of BHEL and any notes, compilations, studies, interpretations, presentations, correspondence or other writing made available to the receiving Party by BHEL whether in physical or electronic form, whether after the effective date or prior to the execution of this agreement, and in specifically marked "**CONFIDENTIAL**", INCLUDING any verbal indication that has been documented in writing and marked as "**Confidential Information**". The receiving Party agrees that all the confidential Information shall be treated as absolute secret and the receiving Party shall not disclose to any person such information otherwise than in accordance with the terms of this Agreement. The Receiving Party will impose a similar duty of confidentiality on any person to whom the Receiving Party is permitted to transfer such information in accordance with the terms hereof.
- (3) The receiving Party shall not, without the prior written consent of BHEL, display or disclose all or any part of the confidential Information, in any manner or circumstances whatsoever, to any person or any third party and all Confidential Information contained herein shall be used by the receiving Party, directly or indirectly solely for the purpose of considering, evaluating and effecting the Project. The receiving Party shall not use the Confidential Information in any way detrimental to BHEL.
- (4) The receiving Party hereby represents that any employee or any official of the Receiving Party who will be given access to the Confidential Information on behalf of the Receiving Party has executed/ shall execute appropriate non-disclosure contracts with the receiving Party for adequate protection of the confidential information belonging to BHEL and/or its Affiliates against disclosure or exploitation. The receiving Party shall forthwith make available a copy of such contracts as and when required BHEL.
- (5) The receiving party shall maintain a record of entities/persons to which the Confidential Information has been disclosed. This record shall be promptly made available to BHEL upon request.
- (6) Without limiting the above, the Receiving Party further undertakes:
  - (i) Not to disclose that the confidential Information is or has been or will be made available or that evaluation of the Confidential Information is being or has been or will be made.
  - (ii) Not to make copies of, or reproduce or display in any form and by any process, all or any of the Confidential Information, except in the form of notes or memoranda, whether in physical or electronic form, made by Receiving Party employees/ officials during their evaluation of the Confidential Information;
  - (iii) To limit the access to the Confidential Information solely to those of its directors, officials or employees who have reason to require access only on a "**need to know**" basis;
  - (iv) To ensure that each of such director, official or employee referred to in Clause 6 (iii) hereinabove, to whom the Confidential Information is disclosed, observes strictly, the restrictions as to use and disclosure contained herein;
  - (v) To return all Confidential Information to BHEL forthwith and within a period of 10 days upon request by BHEL or upon the Receiving Party or BHEL

deciding not to proceed with the Project. Should BHEL permit the destruction of such Confidential Information, the Receiving Party shall destroy the Confidential Information, within the period as may be specified by BHEL and shall provide BHEL with written notice that such destruction has been carried out.

- (vi) To use the Confidential Information solely for the purpose of considering, evaluating and effecting the Project as specified in Schedule 2 hereto and to take all steps necessary to protect the secrecy of the Confidential Information from falling into the public domain or into the possession of unauthorized persons.
  - (vii) To keep confidential the fact of existence of discussions between the Receiving Party and BHEL concerning the Project, unless otherwise required by law and not make any private or public announcement or statement concerning or relating to the Project.
7. The restriction on use and disclosure set out above shall not apply to any Confidential Information which at the date of its disclosure to the Receiving Party is public knowledge or which subsequently becomes public knowledge other than by way of a breach of the terms of this Confidentiality Agreement; Or was available to the Receiving Party prior to its disclosure to the Receiving Party by BHEL under the terms of this Agreement; Party by BHEL under the terms of the Agreement: or is required to be disclosed by way of a legal process regulation or Government order, decree, regulation or rule; Provided herein after that for the purposes of the above section, such circumstances as defined above shall be tangibly proved to the satisfaction of BHEL in order to qualify as an exception under this category.
8. The Receiving Party agrees that all Confidential Information shall remain the property of BHEL or its Affiliates and that BHEL may use such confidential information for many purposes without any obligation to the Receiving Party. Nothing contain herein shall be construed as granting or implying any transfer to rights (including license rights ) to the Receiving Party in the Confidential Information.
9. The Receiving Party agrees and understands that by the furnishing or making available of the confidential information, neither BHEL nor any of its agents are making any representation or warranty express or implied as to the accuracy or completeness of the confidential information. BHEL shall not be liable to the Receiving Party or any other person to use of the confidential information.
10. The Receiving Party shall immediately notify BHEL of any known or suspected breaches of this Agreement and shall give BHEL Full Corporation in any search or security.
11. If either party decodes that it does not wish to proceed with the Project, such party will promptly advice the other party shall forthwith return all confidential information to BHEL and shall not retain any copies of the same, in any form whatever. The receiving Party shall further certify compliance with this clause to BHEL forthwith in writing.
12. The Receiving Party hereby agrees to forth indemnify and hold harmless BHEL and its Affiliates from and against any claim and loss or damages, liability (including the legal fees) arising out of or in connection with any unauthorized or any other breach of

the terms and conditioning contained in this Agreement. This clause shall survive the termination or expiration of this Agreement.

13. The Receiving Party acknowledges that any breach of the terms and conditions of this agreement may cause BHEL irreparable damages for which recovery of money damages would be inadequate. Therefore, the Receiving Party agrees that BHEL or its nominee (in BHEL's sole discretion) shall be entitled, in addition to any other remedies available to it, to seek injunctive relief and/or from its employees/officials, or otherwise to protect its rights, under this Agreement.
14. in the event the Receiving Party is required to disclose Confidential Information upon an action, subpoena or order of a court of competent jurisdiction or of any requirement of legal process regulation or governmental order, decree, regulation or rule, the Receiving Party will immediately notify BHEL of its having received a request to so disclose (alongwith the terms and circumstances thereof), and consult with BHEL on action or steps to be taken in response to such request and shall finally execute any such request in accordance with the satisfaction of BHEL.
15. This Agreement shall be binding upon and shall inure for the benefit of the heirs (if applicable), successors and assigns of the Parties hereto.
16. This Agreement represents the entirety of the agreement of the Parties relating to the disclosure of the Confidential Information and shall not be waived, amended or assigned by either Party except by prior written consent of the other Party. No failure or delay by any party in exercising any right, power or privilege hereunder shall operate as a waiver thereof nor shall any single or partial exercise of any right, power or privilege. The rights and remedies herein provided shall be cumulative and not exclusive of any rights or remedies provided by law.
17. This Agreement may be executed in counterparts, each of which shall be deemed an original, but all of which taken together shall constitute one and the same agreement.
18. If any provision of this Agreement is determined to be unenforceable for any reason, then the remaining provisions hereof shall remain unaffected and in full force and effect.
19. This Agreement, the relationship between the Parties and all rights and obligations arising from any act done or required to be done under this Agreement and the terms herein shall be governed by and construed in accordance with the laws in India. The courts at Mumbai shall have the jurisdiction to try any matters arising out of or in connection herewith.
20. Nothing in this Agreement shall obligate either Party to consummate any transaction discussed as a result hereof.
21. This Agreement shall become binding on the Parties from the Effective Date and shall be in force such tenure as specified in Schedule I and shall remain in force for the entire term of the Project Notwithstanding anything contained herein, the obligations of Receiving Party Under this Agreement to retain secrecy of the Confidential Information shall however survive and be continuing until the Confidential information disclosed by BHEL is no longer confidential and is in public domain without any breach of the terms and conditions hereof by the Receiving Party.
22. Unless otherwise provided herein, all notices or other communications under or in connection with this Agreement shall be given in writing and may be sent by personal delivery or post or courier or facsimile at the address as specified in Schedule I hereto. Any such notice or other communication will be deemed to be effective if sent by personal delivery, when delivered, if sent by post, 4 (four) days after being deposited in the post and if sent by courier, one day after being deposited with the courier, and if sent by facsimile, when sent (on receipt of a confirmation to the correct facsimile number).

23. For the avoidance of the doubt, the owner hereby reserves the right at all times to file for / oblige for any applicable copyright / patent and / or any other licenses as applicable and to this effect the Receiving Party hereby undertake to ensure that there is no infringement of the owner's Intellectual Property Interest (IPR) at any time.

## SCHEDULE I

1. **Effective Date:** \_\_\_\_\_ day of \_\_\_\_\_ (Month).20\_\_\_\_ (year)

2. **The Receiving Party:**

\_\_\_\_\_, a company registered under the provisions of the Companies Act, 1956, and having its Registered Office at \_\_\_\_\_.

The expression "Receiving Party" shall, unless it be repugnant to the subject or context thereof, include its successors and permitted assigns.

3. **Tenure:----** Years

4. **Address for Notices:**

If to BHEL:

BHEL Limited,

BHEL Towers,

Siri Fort

New Delhi 110049

Facsimile Number:

Tel No.:

Attn:

If to the Receiving party:

[Address]

Facsimile Number:

Tel No.:

Attn:

## SCHEDULE 2

### PROJECT

IN WITNESS WHEREOF, the Parties have caused the Agreement to be executed in the manner hereinafter appearing.

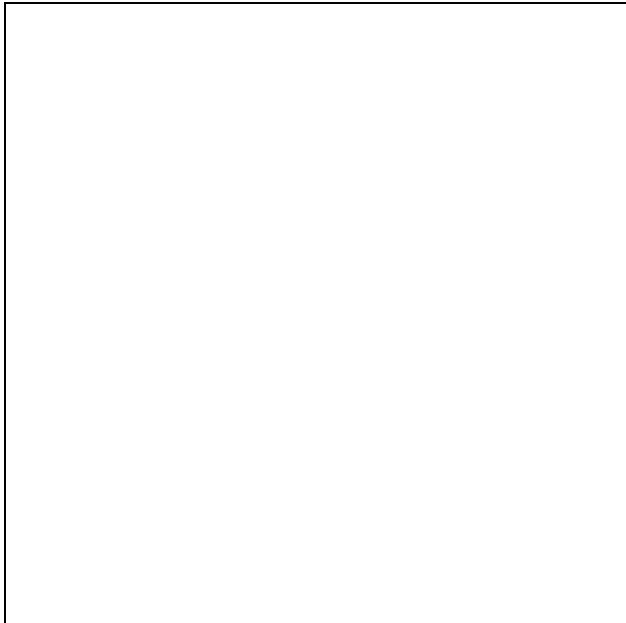

In the presence of:

1)

2)

AND

Signed and Delivered by BHEL  
LIMITED, the within named BHEL by the  
Hand of \_\_\_\_\_, its  
Authorized official in the presence of:

1) \_\_\_\_\_;

2) \_\_\_\_\_.



**Certificate by Chartered Accountant on letter head**

This is to Certify that M/s.....,  
(hereinafter referred to as 'company') having its registered office at .....  
Is registered under MSMED Act 2006, (Entrepreneur Memorandum No (Part-II).....  
Dtd:....., Category:.....(Micro/Small). (Copy enclosed).

Further verified from the Books of Accounts that the investment of the company as on  
date..... as per MSMED Act 2006 is as follows:

1. **For Manufacturing Enterprises:** Investment in plant and machinery (i.e. original cost excluding land and building and the items specified by the Ministry of Small Scale Industries vide its notification No.S.O.1722 (E) dated October 5, 2006:  
Rs.....Lacs
2. **For Service Enterprises:** Investment in equipment (original cost excluding land building and furniture, fittings and other items not directly related to the service rendered or as may be notified under the MSMED Act, 2006:  
Rs.....Lacs

**(Strike off whichever is not applicable)**

The above investment of Rs.....Lacs is within permissible limit of Rs.....Lacs for .....Micro / Small (Strike off which is not applicable) Category under MSMED Act 2006.

Or

The company has been graduated from its original category (Micro / Small) (Strike off which is not applicable) and the date of graduation of such enterprise from its original category is .....(dd/mm/yyyy) which is within the period of 3 years from the date of graduation of such enterprise from its original category as notified vide S.O.No. 3322 (E) dated 01.11.2013 published in the gazette notification dated 04.11.2013 by Ministry of MSME.

Date:

(Signature)

Name –

Membership number-

Seal of Chartered Accountant

## **INTEGRITY PACT**

### **Between**

Bharat Heavy Electricals Ltd. (BHEL), a company registered under the Companies Act 1956 and having its registered office at "BHEL House", Siri Fort, New Delhi – 110049 (India) hereinafter referred to as "The Principal", which expression unless repugnant to the context or meaning hereof shall include its successors or assigns of the ONE PART

### **and**

\_\_\_\_\_, (description of the party along with address), hereinafter referred to as "The Bidder/ Contractor" which expression unless repugnant to the context or meaning hereof shall include its successors or assigns of the OTHER PART

### **Preamble**

The Principal intends to award, under laid-down organizational procedures, contract/s for

\_\_\_\_\_  
\_\_\_\_\_. The Principal values full compliance with all relevant laws of the land, rules and regulations, and the principles of economic use of resources, and of fairness and transparency in its relations with its Bidder(s)/ Contractor(s).

In order to achieve these goals, the Principal will appoint Independent External Monitor(s), who will monitor the tender process and the execution of the contract for compliance with the principles mentioned above.

## **Section 1 – Commitments of the Principal**

- 1.1 The Principal commits itself to take all measures necessary to prevent corruption and to observe the following principles:-
  - 1.1.1 No employee of the Principal, personally or through family members, will in connection with the tender for, or the execution of a contract, demand, take a promise for or accept, for self or third person, any material or immaterial benefit which the person is not legally entitled to.
  - 1.1.2 The Principal will, during the tender process treat all Bidder(s) with equity and reason. The Principal will in particular, before and during the tender process, provide to all Bidder(s) the same information and will not provide to any Bidder(s) confidential / additional information through which the Bidder(s) could obtain an advantage in relation to the tender process or the contract execution.
  - 1.1.3 The Principal will exclude from the process all known prejudiced persons.
- 1.2 If the Principal obtains information on the conduct of any of its employees which is a penal offence under the Indian Penal Code 1860 and Prevention of Corruption Act 1988 or any other statutory penal enactment, or if there be a substantive suspicion in this regard, the Principal will inform its Vigilance Office and in addition can initiate disciplinary actions.

## **Section 2 – Commitments of the Bidder(s)/ Contractor(s)**

- 2.1 The Bidder(s)/ Contractor(s) commit himself to take all measures necessary to prevent corruption. He commits himself to observe the following principles during his participation in the tender process and during the contract execution.
  - 2.1.1 The Bidder(s)/ Contractor(s) will not, directly or through any other person or firm, offer, promise or give to the Principal or to any of the Principal's employees involved

in the tender process or the execution of the contract or to any third person any material, immaterial or any other benefit which he / she is not legally entitled to, in order to obtain in exchange any advantage of any kind whatsoever during the tender process or during the execution of the contract.

- 2.1.2 The Bidder(s)/ Contractor(s) will not enter with other Bidder(s) into any illegal or undisclosed agreement or understanding, whether formal or informal. This applies in particular to prices, specifications, certifications, subsidiary contracts, submission or non-submission of bids or any other actions to restrict competitiveness or to introduce cartelization in the bidding process.
- 2.1.3 The Bidder(s)/ Contractor(s) will not commit any penal offence under the relevant IPC/ PC Act; further the Bidder(s)/ Contractor(s) will not use improperly, for purposes of competition or personal gain, or pass on to others, any information or document provided by the Principal as part of the business relationship, regarding plans, technical proposals and business details, including information contained or transmitted electronically.
- 2.1.4 The Bidder(s)/ Contractor(s) will, when presenting his bid, disclose any and all payments he has made, and is committed to or intends to make to agents, brokers or any other intermediaries in connection with the award of the contract.
- 2.2 The Bidder(s)/ Contractor(s) will not instigate third persons to commit offences outlined above or be an accessory to such offences.



### **Section 3 – Disqualification from tender process and exclusion from future contracts**

If the Bidder(s)/ Contractor(s), before award or during execution has committed a transgression through a violation of Section 2 above, or acts in any other manner such as to put his reliability or credibility in question, the Principal is entitled to disqualify the Bidder(s)/ Contractor(s) from the tender process or take action as per the separate "Guidelines on Banning of Business dealings with Suppliers/ Contractors". framed by the Principal.

### **Section 4 – Compensation for Damages**

- 4.1 If the Principal has disqualified the Bidder from the tender process prior to the award according to Section 3, the Principal is entitled to demand and recover the damages equivalent Earnest Money Deposit/Bid Security.
- 4.2 If the Principal has terminated the contract according to Section 3, or if the Principal is entitled to terminate the contract according to section 3, the Principal shall be entitled to demand and recover from the Contractor liquidated damages equivalent to 5% of the contract value or the amount equivalent to Security Deposit/Performance Bank Guarantee, whichever is higher.

### **Section 5 – Previous Transgression**

- 5.1 The Bidder declares that no previous transgressions occurred in the last 3 years with any other company in any country conforming to the anti-corruption approach or with any other Public Sector Enterprise in India that could justify his exclusion from the tender process.
- 5.2 If the Bidder makes incorrect statement on this subject, he can be disqualified from the tender process or the contract, if already awarded, can be terminated for such reason.

## **Section 6 – Equal treatment of all Bidders/ Contractors/ Sub-contractors**

- 6.1 The Bidder(s)/ Contractor(s) undertake(s) to obtain from all subcontractors a commitment consistent with this Integrity Pact and report Compliance to the Principal. This commitment shall be taken only from those sub-contractors whose contract value is more than 20 % of Bidder's/ Contractor's contract value with the Principal. The Bidder(s)/ Contractor(s) shall continue to remain responsible for any default by his Sub-contractor(s).
- 6.2 The Principal will enter into agreements with identical conditions as this one with all Bidders and Contractors.
- 6.3 The Principal will disqualify from the tender process all bidders who do not sign this pact or violate its provisions.

## **Section 7 – Criminal Charges against violating Bidders/ Contractors /Sub-contractors**

If the Principal obtains knowledge of conduct of a Bidder, Contractor or Subcontractor, or of an employee or a representative or an associate of a Bidder, Contractor or Subcontractor which constitutes corruption, or if the Principal has substantive suspicion in this regard, the Principal will inform the Vigilance Office.

## **Section 8 –Independent External Monitor(s)**

- 8.1 The Principal appoints competent and credible Independent External Monitor for this Pact. The task of the Monitor is to review independently and objectively, whether and to what extent the parties comply with the obligations under this agreement.

- 8.2 The Monitor is not subject to instructions by the representatives of the parties and performs his functions neutrally and independently. He reports to the CMD, BHEL.
- 8.3 The Bidder(s)/ Contractor(s) accepts that the Monitor has the right to access without restriction to all contract documentation of the Principal including that provided by the Bidder(s)/ Contractor(s). The Bidder(s)/ Contractor(s) will grant the monitor, upon his request and demonstration of a valid interest, unrestricted and unconditional access to his contract documentation. The same is applicable to Sub-contractor(s). The Monitor is under contractual obligation to treat the information and documents of the Bidder(s)/ Contractor(s) / Sub-contractor(s) with confidentiality.
- 8.4 The Principal will provide to the Monitor sufficient information about all meetings among the parties related to the contract provided such meetings could have an impact on the contractual relations between the Principal and the Contractor. The parties offer to the Monitor the option to participate in such meetings.
- 8.5 As soon as the Monitor notices, or believes to notice, a violation of this agreement, he will so inform the Management of the Principal and request the Management to discontinue or take corrective action, or heal the situation, or to take other relevant action. The Monitor can in this regard submit non-binding recommendations. Beyond this, the Monitor has no right to demand from the parties that they act in a specific manner, refrain from action or tolerate action.
- 8.6 The Monitor will submit a written report to the CMD, BHEL within 8 to 10 weeks from the date of reference or intimation to him by the Principal and, should the occasion arise, submit proposals for correcting problematic situations.
- 8.7 The CMD, BHEL shall decide the compensation to be paid to the Monitor and its terms and conditions.
- 8.8 If the Monitor has reported to the CMD, BHEL, a substantiated suspicion of an offence under relevant IPC / PC Act, and the CMD, BHEL has not, within reasonable time, taken visible action to proceed against such offence or reported it to the Vigilance Office, the



Monitor may also transmit this information directly to the Central Vigilance Commissioner, Government of India.

8.9 The number of Independent External Monitor(s) shall be decided by the CMD, BHEL.

8.10 The word 'Monitor' would include both singular and plural.

### **Section 9 – Pact Duration**

9.1 This Pact begins and shall be binding on and from the submission of bid(s) by bidder(s). It expires for the Contractor 12 months after the last payment under the respective contract and for all other Bidders 6 months after the contract has been awarded.

9.2 If any claim is made / lodged during this time, the same shall be binding and continue to be valid despite the lapse of this pact as specified as above, unless it is discharged/ determined by the CMD, BHEL.

### **Section 10 – Other Provisions**

10.1 This agreement is subject to Indian Laws and jurisdiction shall be registered office of the Principal, i.e. New Delhi.

10.2 Changes and supplements as well as termination notices need to be made in writing. Side agreements have not been made.

10.3 If the Contractor is a partnership or a consortium, this agreement must be signed by all partners or consortium members.

10.4 Should one or several provisions of this agreement turn out to be invalid, the remainder of this agreement remains valid. In this case, the parties will strive to come to an agreement to their original intentions.



10.5 Only those bidders/ contractors who have entered into this agreement with the Principal would be competent to participate in the bidding. In other words, entering into this agreement would be a preliminary qualification.

-----

-----

For & On behalf of the Principal

For & On behalf of the Bidder/ Contractor

(Office Seal)

(Office Seal)

Place-----

Date-----

Witness: \_\_\_\_\_

Witness: \_\_\_\_\_

(Name & Address) \_\_\_\_\_

(Name & Address) \_\_\_\_\_

\_\_\_\_\_

\_\_\_\_\_

**GUIDELINES FOR  
REVERSE AUCTION-2016**  
*enabling*

*Execution, Consolidation, Simplification (ECS)*

**(AA:SSP:RA:03)**

Issued on 26.09.2016

**Sourcing Strategy & Policy  
Corporate Operations Management  
BHEL, New Delhi**

Annexure – I

Business Rules for Reverse Auction

This has reference to tender no {-----}. BHEL shall finalize the Rates for the supply of {item name} through Reverse Auction mode. BHEL has made arrangement with Service Provider who shall be BHEL's authorized service provider for the same. Bidders should go through the instructions given below and submit acceptance of the same.

The technical & commercial terms are as per (a) BHEL Tender Enq. No. {-----}, (b) Bidders' technical & commercial bid (in case of two-part bid) and (c) subsequent correspondences between BHEL and the bidders, if any.

**1. Procedure of Reverse Auctioning**

- i. **Online Sealed Bid:** This duration of online sealed bid will be {-----} minutes. All bidders to submit their online sealed bids during this period.
- ii. **Online Reverse Auction:** The 'opening price' i.e. start price for RA and 'bid decrement' will be decided by BHEL.
- iii. If BHEL decides the lowest online sealed bid as the starting price, then the lowest bidder in online sealed bid shall be shown as current L1 automatically by the system and no acceptance of that price is required. System shall have the provision to indicate this bid as current L1.
- iv. Bidders by offering a minimum bid decrement or the multiples thereof can displace a standing lowest bid and become "L1" and this continues as an iterative process.
- v. After the completion of the online reverse auction, the Closing Price (CP) shall be available for further processing.

**2. Schedule for Reverse Auction:** The Reverse Auction is tentatively scheduled on {-----} and the duration of online sealed bid will be {-----} minutes. All bidders to submit their online sealed bids during this period.

- **Online Sealed Bid:-**
  - *Start Time:* {-----}
  - *Close Time:* {-----}
- **Online Reverse Auction:-**
  - *Start Time:* {-----}
  - *Close Time:* {-----}

**3. Auction extension time:** If a bidder places a bid in the last {-----} minutes of closing of the Reverse Auction and if that bid gets accepted, then the auction's duration shall get extended automatically for another {-----} minutes, for the entire auction (i.e. for all the items in the auction), from the time that bid comes in. Please note that the auto-extension will take place

only if a bid comes in those last {-----} minutes and if that bid gets accepted as the lowest bid. If the bid does not get accepted as the lowest bid, the auto-extension will not take place even if that bid might have come in the last {-----} minutes. In case, there is no bid in the last {-----} minutes of closing of Reverse Auction, the auction shall get closed automatically without any extension. However, bidders are advised not to wait till the last minute or last few seconds to enter their bid during the auto-extension period to avoid complications related with internet connectivity, network problems, system crash down, power failure, etc.

The above process will continue till completion of Reverse Auction.

Complaints/ Grievances, if any, regarding denial of service or any related issue should be given in writing thru e-mail/ fax to Service Provider with a copy to BHEL within 15 minutes prior to initial closing time of Online Reverse Auction.

4. **Bid price:** The Bidder has to quote the **FOR BHEL Price (or) CIP Mumbai**, Price inclusive of Packing & Forwarding charges, all the routine & type tests as per tender scope, ED + cess, CST against C-form, Freight (bidder to provide original Freight paid receipt), insurance charges, etc. including loading (if indicated by BHEL due to deviations in technical/ commercial terms) for the Items specified. Details are as shown in Excel Sheet for calculation of total cost to BHEL (To be specified by Unit as per NIT conditions).
5. **Bidding currency and unit of measurement:** Bidding will be conducted in *Indian Rupees per Unit* of the material as per the specifications.  
  
In case of foreign currency bids, exchange rate (TT selling rate of State Bank of India) as on scheduled date of tender opening (Part-I bid) shall be considered for conversion in Indian Rupees. If the relevant day happens to be a Bank holiday, then the forex rate as on the previous bank (SBI) working day shall be taken.
6. **Validity of bids:** Price shall be valid for {-----} from the date of reverse auction. These shall not be subjected to any change whatsoever.
7. **Lowest bid of a bidder:** In case the bidder submits more than one bid, the lowest bid at the end of Online Reverse Auction will be considered as the bidder's final offer to execute the work.
8. Bidders shall be assigned a **Unique User Name & Password** by Service Provider. Bidders are advised to change the Password and edit the information in the Registration Page after the receipt of initial Password from Service Provider to ensure confidentiality. All bids made from the Login ID given to the bidders will be deemed to have been made by the bidders / bidders' company.

9. **Post auction procedure:** BHEL will proceed with the Lowest Bid in the Reverse Auction for further processing.
10. Any commercial/ technical loading shall be intimated to bidders prior to RA. The excel sheet provided in this regard shall cover all these aspects. Commercial/ technical loading if any, shall be added by the respective bidder in its price during online sealed bid & Online Reverse Auction. Modalities of loading & de-loading shall be separately intimated to the bidders. The responsibility for correctness of total cost to BHEL shall lie with the bidders.
11. Computerized reverse auction shall be conducted by BHEL (through Service Provider), on pre-specified date, while the bidders shall be quoting from their own offices/ place of their choice. Internet connectivity shall have to be ensured by bidders themselves.

During the RA process if a bidder is not able to bid and requests for extension of time by FAX/ email/ phone then time extension of additional 15 minutes will be given by the service provider provided such requests come before 5 minutes of auction closing time. However, only one such request per bidder can be entertained.

Despite this extension if bidder fails to upload his prices due to extreme case of failure of Internet connectivity, (due to any reason whatsoever may be) it is the bidders' responsibility/ decision to send fax communication immediately to Service Provider furnishing the price the bidder wants to bid online with a request to the service provider to upload the faxed price online so that the service provider will upload that price online on behalf of the Bidder. It shall be noted clearly that the concerned bidder communicating this price to service provider has to solely ensure that the fax message is received by the service provider in a readable/ legible form and also the Bidder should simultaneously check up with service provider about the clear receipt of the price faxed. It shall also be clearly understood that the bidder shall be at liberty to send such fax communications of prices to be uploaded by the service provider only within the closure of Bid time and under no circumstance it shall be allowed beyond the closure of Bid time /reverse auction. It shall also be noted that the service provider should be given a reasonable required time by the bidders, to upload such prices online and if such required time is not available at the disposal of the Service provider at the time of receipt of the fax message from the bidders, the service provider will not be uploading the prices and either BHEL or the service provider are not responsible for this unforeseen circumstances. In order to ward-off such contingent situation bidders are requested to make all the necessary arrangements/ alternatives whatever required so that they are able to circumvent such situation and still be able to participate in the reverse auction successfully. Failure of power or loss of connectivity at the premises of bidders during the Reverse auction cannot be the cause for not participating in the reverse auction. On account of this, the time for the auction cannot be extended and neither BHEL nor Service Provider is responsible for such eventualities.

12. Proxy bids: Proxy bidding feature is a pro-bidder feature to safeguard the bidder's interest of any internet failure or to avoid last minute rush. The proxy feature allows bidders to place an automated bid in the system directly in an auction and bid without having to enter a new amount each time a competing bidder submits a new offer. The bid amount that a bidder enters is the minimum that the bidder is willing to offer. Here the software bids on behalf of the bidder. This obviates the need for the bidder participating in the bidding process until the proxy bid amount is decrementally reached by other bidders. When proxy bid amount is reached, the bidder (who has submitted the proxy bid) has an option to start participating in the bidding process.

The proxy amount is the minimum amount that the bidder is willing to offer. During the course of bidding, the bidder cannot delete or change the amount of a proxy bid.

Bids are submitted in decrements (decreasing bid amounts). The application automates proxy bidding by processing proxy bids automatically, according to the decrement that the auction originator originally established when creating the auction, submitting offers to the next bid decrement each time a competing bidder bids, regardless of the fact whether the competing bids are submitted as proxy or standard bids. However, it may please be noted that if a manual bid and proxy bid are submitted at the same instant manual bid will be recognized as the L1 at that instant.

In case of more than one proxy bid, the system shall bid till it crosses the threshold value of 'each lowest proxy bid' and thereafter allow the competition to decide the final L1 price.

Proxy bids are fed into the system directly by the respective bidders. As such this information is privy only to the respective bidder(s).

13. Bidders are advised to get fully trained and clear all their doubts such as refreshing of screen, quantity being auctioned, tender value being auctioned etc from Service Provider.
14. Service Provider shall arrange to demonstrate/ train the bidder or bidder's nominated person(s), without any cost to bidders. Service Provider shall also explain the bidders, all the business rules related to the Reverse Auction. Bidders are required to submit their acceptance to the terms/ conditions/ modalities before participating in the Reverse Auction in the process compliance form as enclosed. Without this, the bidder will not be eligible to participate in the event.
15. Successful bidder shall be required to submit the final prices (L1) in prescribed format (Annexure-VI) for price breakup including that of line items, if required, quoted during the Online Reverse Auction, duly signed and stamped as token of acceptance without any new condition (other than those already agreed to before start of auction), after the completion of auction to Service Provider besides BHEL within two working days of Auction without fail.

16. Any variation between the final bid value and that in the confirmatory signed price breakup document will be considered as tampering the tender process and will invite action by BHEL as per extant guidelines for suspension of business dealings (as available on [www.bhel.com](http://www.bhel.com)).
17. Bidders' bid will be taken as an offer to execute the work/ supplies of the item as per enquiry no. {...} dt. {...}. Bids once made by the bidder, cannot be cancelled/ withdrawn and bidder shall be bound to execute the work as mentioned above at bidder's final bid price. Should bidder back out and not execute the contract as per the rates quoted, BHEL shall take action as per extant guidelines for suspension of business dealings (as available on [www.bhel.com](http://www.bhel.com)).
18. Bidders shall be able to view the following on their screen along with the necessary fields during Online Reverse Auction:
  - a) Leading (Running Lowest) Bid in the Auction (only total price of package).
  - b) Bid Placed by the bidder.
  - c) Start Price.
  - d) Decrement value.
  - e) Rank of their own bid during bidding as well as at the close of auction.
19. BHEL's decision on award of contract shall be final and binding on all the Bidders.
20. BHEL reserves the right to extend, reschedule or cancel the Reverse Auction process at any time, before ordering, without assigning any reason, with intimation to bidders.
21. BHEL shall not have any liability to bidders for any interruption or delay in access to the site irrespective of the cause. In such cases, the decision of BHEL shall be binding on the bidders.
22. Other terms and conditions shall be as per bidder's techno-commercial offers and other correspondences, if any, till date.
23. If there is any clash between this business document and the FAQ available, if any, in the website of Service Provider the terms & conditions given in this business document will supercede the information contained in the FAQs. Any changes made by BHEL/ service provider (due to unforeseen contingencies) after the first posting shall be deemed to have been accepted if the bidder continues to access the portal after that time.
24. Bidder shall not divulge either his Bids or any other exclusive details of BHEL to any other party. If the Bidder or any of his representatives are found to be involved in Price manipulation/ cartel formation of any kind, directly or indirectly by communicating with other bidders, action as per extant BHEL guidelines for suspension of business dealings (as available on [www.bhel.com](http://www.bhel.com)), shall be initiated by BHEL.



**Annexure-II**

**Mandate to Service Provider**

Ref : **Enquiry No.**

Date :

To,

*Service Provider*

Sub: Providing of Services for Reverse Auction.

Ref: No **Enquiry No. & Date**

Dear Sirs,

Please conduct Reverse Auction as per the following details:

- **Scope:** Auction event management with training of BHEL and its bidders.
- Ensure process compliance form from all the bidders before start of RA event. In case of postponement of event to some other date, ensure acknowledgement from each bidder.
- Price: Rs. {.....}/- . No other duties, Taxes, levies etc. except service tax @ {.....}% shall be payable for conducting reverse auction. This price is firm.
- Payment Terms: 100% payment after successful completion of Auction.
- Completion of Auction: The auction shall be deemed to have been successfully completed on receipt and acceptance of final report including hard copy of the final bid with price break up including that of line items, if any, duly signed by the successful bidder who has participated in the reverse auction. The bill shall be submitted along with the completion report to the undersigned.
- Business Rules of the Reverse Auction are as per Annexure-I
- The list of bidders with their contact details is given in Annexure-IV. and the details of the item (s) to be Reverse Auctioned are as per Annexure-V.
- Please acknowledge receipt of this letter order and also confirm that final report (duly signed and stamped by Service Provider) including hard copy of the final bid with breakup of prices including that of line items duly signed by the successful bidder (duly endorsed by Service Provider) shall be submitted within four working days of conclusion of auction.

Yours sincerely,  
(for and on behalf of BHEL)

**Note:**

- i) The case of rescheduled auction event will be considered separate event for the purpose of payment.
- ii) If the event has been conducted as per mandate, you shall be paid irrespective of RA outcome.

<b>Buyer Name</b>	<b>BHARAT HEAVY ELECTRICALS LIMITED, RAMACHANDRA PURAM PURCHASE (HE&amp;F) HYDERABAD 502 032</b>
	<b><u>Contact Person Details:</u></b>
<b>Auction to be conducted by</b>	
<b>Date of Auction</b>	
<b>Documents Attached: (To be sent to the bidders)</b>	<ol style="list-style-type: none"> <li>1) Business rules for Reverse Auction (Annexure-I)</li> <li>2) Process Compliance Form (Annexure-III)</li> <li>3) Details of item (s) to be Reverse Auctioned (Annexure-V)</li> <li>4) Post RA Price confirmation by bidder (Annexure-VI)</li> </ol>

**Annexure – III**

**Process Compliance Form**

**(The bidders are required to print this on their company's letterhead and sign, stamp before RA)**

To

*Service Provider*

**Sub: Agreement to the Process related Terms and Conditions**

Dear Sir,

This has reference to the Terms & Conditions for the Reverse Auction mentioned in the RFQ document for {Items} against BHEL enquiry no. {-----}

This letter is to confirm that:

- 1) The undersigned is authorized official/ representative of the company to participate in RA and to sign the related documents.
- 2) We have studied the Reverse Auction guidelines (as available on www.bhel.com), and the Business rules governing the Reverse Auction as mentioned in your letter and confirm our agreement to them.
- 3) We also confirm that we have taken the training on the auction tool and have understood the functionality of the same thoroughly.
- 4) We also confirm that, in case we become L1 bidder, we will FAX/ email/ the price confirmation & break up of our quoted price (including that of line items) as per Annexure-VI within two working days (of BHEL) after completion of RA event, besides sending the same by registered post/ courier both to M/s. BHEL and Service Provider
- 5) We also confirm that in case we become L1 bidder, the envelope sealed price bid submitted by us shall be opened by BHEL and we agree to accept the lower of the two bids (RA closing price & envelope sealed price) for placement of order and we have understood that in case online sealed bid placed by us is found higher than envelope sealed price bid submitted by us, then BHEL may take action as stipulated in NIT.

We, hereby confirm that we will honor the Bids placed by us during the auction process.

With regards

Signature with company seal

Name –

Company / Organization

Designation within Company / Organization

Address of Company / Organization

- Sign this document and FAX/ email it to Service Provider at {.....} prior to start of the Event.

**Annexure – IV**

**List of bidders and their address/ contact person details**

<b>S. No.</b>	<b>Address</b>	<b>Contact Person</b>
1		
2		
3		
4		

**Annexure – V**

**Details of item (s) to be Reverse Auctioned**

*Details of items including quantity, specification, Enquiry no. {-----}*

The offers of all the bidders are technically & commercially frozen as submitted by the bidders and clarified in subsequent correspondence, if any, with the bidders.

**Annexure – VI**

**RA price confirmation and breakup**  
**(To be submitted by L1 bidder after completion of RA)**

To

Service Provider

CC: **BHARAT HEAVY ELECTRICALS LIMITED**  
**PURCHASE (HE&F)**  
**HYDERABAD 502 032**

**Sub: Final price quoted during Reverse Auction and price breakup**

Dear Sir,

We confirm that we have quoted.

Rs. { \_\_\_\_\_ in value & in words \_\_\_\_\_ } for item(s) covered under tender enquiry No. {--  
----}.

Total price of the items covered under above cited enquiries is inclusive of {Packing & forwarding, E.D., C.S.T., freight and insurance charges upto {.....} District,{.....} State and Type Test Charges etc., (exclusive of service tax), other as per NIT}

as our final landed prices as quoted during the Reverse Auction conducted today {date} which will be valid for a period of {-----} days.

The price break-up including that of line items is as given below.

Total \_\_\_\_\_ - \_\_\_\_\_  
Rs. \_\_\_\_\_  
\_\_\_\_\_

Thanking you and looking forward to the valuable order from BHEL.

Yours sincerely,

For \_\_\_\_\_

**Name:**  
**Company:**  
**Date:**  
**Seal:**



**Name of the proposed Equipment / Item / Process with Model / Type / Rating / Capacity / Size / Tonnage etc. (As applicable):**

\_\_\_\_\_

\_\_\_\_\_

1. **Name of Proposed Sub-Supplier:** \_\_\_\_\_

**Website:** \_\_\_\_\_

2. **Address of Regd. Office:**

\_\_\_\_\_  
\_\_\_\_\_  
\_\_\_\_\_

**Details of contact person:**

Name \_\_\_\_\_

Mobile no. \_\_\_\_\_

Desig. \_\_\_\_\_

E-mail:

• **Country of Head Office**

\_\_\_\_\_

• **Field of activitie**

\_\_\_\_\_

3. **Address of Works where Item is being manufactured**

\_\_\_\_\_  
\_\_\_\_\_  
\_\_\_\_\_

**Details of contact person:**

Name \_\_\_\_\_

Mobile no. \_\_\_\_\_

Desig. \_\_\_\_\_

E-mail:

4. **Branch / Liaison office in Dhaka**

\_\_\_\_\_  
\_\_\_\_\_  
\_\_\_\_\_

**Details of contact person:**

Name \_\_\_\_\_

Mobile no. \_\_\_\_\_

Desig. \_\_\_\_\_

E-mail:





**5. Details of Proposed Works:**

- a. Year of Establishment of present works: \_\_\_\_\_
- b. Year of Commencement of: \_\_\_\_\_  
Manufacturing at the above works
- c. Details of change in works address in past, if any : \_\_\_\_\_
- d. Total Covered Area : \_\_\_\_\_
- e. Details of covered area like no. of sheds, : \_\_\_\_\_  
Area of each shed etc.
- f. Electric power- Connected load: \_\_\_\_\_  
Electric power- Stand by load & system: \_\_\_\_\_

**6. Annual Turnover & Profit in past three years :** \_\_\_\_\_  
 \_\_\_\_\_  
 \_\_\_\_\_

- 7. Do you have in-house Department for**
- a) Design Yes / No
  - b) Research & Development Yes / No
  - c) Quality control/Inspection Yes / No
  - d) After Sales Service Yes / No

If any of these items answered with “No”, an explanation shall be provided.

**8. Shift works per day** One / Two / Three  
**Weekly day off**

**9. Present Manpower Status:**

Division Status	Graduate		Diploma	Skilled	Un-Skilled	Remarks
	Technical	Non-Technical				
Design						
Production						
Quality Control / Inspection						
After Sales Service						



## SUB-SUPPLIER QUESTIONNAIRE

**FICHTNER**

- a. Enclose organization chart of the proposed works (Y / N) \_\_\_\_\_
- b. Enclose Organization chart of QA / QC Deptt. (Y / N) \_\_\_\_\_
- c. Enclose List of Qualified Welders with process etc. (Y / N) \_\_\_\_\_
- d. Enclose List of Qualified NDT personnel with area of specialization (Y / N) \_\_\_\_\_

10. **Trade Name of Product (if any)** \_\_\_\_\_

11. **Brief details of items manufactured:**

Sl. No.	Item & Material (Type / Size / Rating / Model / Tonnage, as applicable)	Installed Capacity	Annual Production Capacity	Annual Production for last Three years		
				I	II	III

12. **Details of foreign Collaboration, if any:**

Sl. No.	Product	Name & Address of Collaborator	Collaboration		
			Scope	Year	Valid upto



13. **Furnish Type Test report for the proposed product (if applicable).**

---

14. **Approval/Certification by National/International standards/accredited agency applicable for the proposed product (if applicable).**

---

15. **Furnish statutory/mandatory certification for proposed product (if applicable).**

---

16. **Furnish supply Experience list of the proposed product.**

List shall include Item description (Type / Size / Rating / Model / Tonnage, as applicable), Customer name, Quantity, Year of Supply, and Year of commissioning.

---

17. **Enclose End User's operational feedback certificate for the proposed product.**

---

18. **Enclose list of equipment & machinery specific to the proposed product.**

This should include name of equipment, capacity & nos. etc.:

---

19. **Enclose Process Flow Diagram indicating in-house & outsourced process.**

---



**20. General manufacturing facilities available:**

Sl. No.	Description of machine	Inhouse		Outsourced	
		Capacity	No.	Capacity	No.
a)	Material Handling Mobile Crane Fork Lift Over Head Cranes				
b)	Metal Cutting & Bending				
c)	Casting				
d)	Forging				
e)	Fabrication				
f)	Welding				
g)	Machining				
h)	Heat Treatment				
i)	Surface & Cleaning Sand Blasting Shot Blasting Pickling				
j)	Painting				
k)	Metal Coating				
l)	Packing				
m)	Other, if any				

**21. Enclose Testing & Inspection facilities specific to the proposed product:**

- a. In-house \_\_\_\_\_
- b. Outsourced \_\_\_\_\_

**22. Storage of finished goods (covered / open).** \_\_\_\_\_



- 23 **Enclose list of the source / make with location of major raw material, bought out items and out sourced process** \_\_\_\_\_
24. **Furnish details regarding local service support and spare parts availability in Bangladesh. process** \_\_\_\_\_
25. **Quality management**
- 25.1 General
- 25.1.1 Work Instruction for different processes available. (Y / N) \_\_\_\_\_  
if yes, furnish list.
- 25.1.2 Evaluation system for raw material / bought out item's supplier is available. (Y / N) \_\_\_\_\_
- 25.1.3 Records generated during inspection maintained & available for review? (Y / N) \_\_\_\_\_
- 25.1.4 Statistical quality control techniques used? (Y/N) If yes please furnish details. (Y / N) \_\_\_\_\_
- 25.1.5 ISO certificate for the works available? (Y / N) \_\_\_\_\_  
If yes, enclose copy of the certificate.
- 25.1.6 Quality & HSE Manual for the works available (Y / N) \_\_\_\_\_  
If yes, enclose copy of the manual.
- 25.2 Corrective action
- 25.2.1 Specifically confirm whether System for identifying & disposition of Non Conformity in the process / product is available (Y / N) \_\_\_\_\_
- 25.2.2 Specifically confirm whether System for Customer complains & their satisfactory disposal is available. (Y / N) \_\_\_\_\_
- 25.3. Documentation Control
- 25.3.1 Procedure available for documentation control (Y / N) \_\_\_\_\_
- 25.4. Control of Inspection, measuring & testing equipments.
- 25.4.1 Procedure for calibration of testing & measuring instrument available. (Y / N) \_\_\_\_\_



**27. Certification of sub-supplier**

**I CERTIFY THAT THE INFORMATION SUPPLIED HEREIN (INCLUDING ALL PAGES ATTACHED) IS CORRECT.**

**SEAL**  
  
M/S. \_\_\_\_\_  
PLACE \_\_\_\_\_  
  
DATE \_\_\_\_\_

**SIGNATURE** \_\_\_\_\_  
**NAME** \_\_\_\_\_  
**DESIGNATION** \_\_\_\_\_  
**MOBILE NO** \_\_\_\_\_  
**EMAIL** \_\_\_\_\_

LIST OF ENCLOSURE:

**28. Certification by Main Supplier:**

**ABOVE INFORMATION HAVE BEEN VERIFIED AND FOUND IN ORDER TO COMPLY WITH TECHNICAL SPECIFICATION AS PER EPC-CONTRACT.**

**Name:** \_\_\_\_\_ **Designation:** \_\_\_\_\_ **Signature:** \_\_\_\_\_ **Date:** \_\_\_\_\_

**NOTE:**

- 1. COLUMN SHALL NOT BE LEFT UNFILLED. IN CASE OF NOT APPLICABLE / NOT AVAILABLE, THE SAME SHALL BE INDICATED IN THE PROVIDED SPACE.**
- 2. IN CASE PROVIDED SPACE IS NOT ADEQUATE, INFORMATION SHALL BE PROVIDED AS AN ATTACHMENT.**
- 3. PRODUCT CATALOGUE FOR THE PROPOSED EQUIPMENT / ITEM / PROCESS, IF AVAILABLE, SHALL BE ENCLOSED**